

# PDW30 Point-to-Point Wireless Bridge Instruction Manual



## Wireless System

- Signal Wire Replacement in a Rugged, Industrial Housing
- Simple to Order, Configure, & Install
- Range: 1 Mile Line-of-Sight, 500 ft. Indoor
- Analog & Digital Inputs and Outputs, RS-485 Communications
- Remote or Attached Antenna
- Repeaters and Directional Antennae Available
- Flanges for Wall or Pipe Mounting
- PC Software Available for Even Easier Setup
- Rugged, NEMA 4X/IP68 Enclosure



### PRECISION DIGITAL CORPORATION

233 South Street • Hopkinton MA 01748 USA  
Tel (800) 343-1001 • Fax (508) 655-8990

**PRECISION  
DIGITAL**   
**WIRELESS**  
www.predig.com

## Disclaimer

The information contained in this document is subject to change without notice. Precision Digital makes no representations or warranties with respect to the contents hereof and specifically disclaims any implied warranties of merchantability or fitness for a particular purpose.

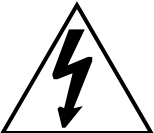
 <p><b>Caution:</b> <i>Read complete instructions prior to installation and operation of the meter.</i></p>	 <p><b>Warning:</b> <i>Risk of electric shock or personal injury.</i></p>
 <p><b>Warning!</b></p>	<p><b><i>This product is not recommended for life support applications or applications where malfunctioning could result in personal injury or property loss. Anyone using this product for such applications does so at their own risk. Precision Digital Corporation shall not be held liable for damages resulting from such improper use.</i></b></p>

## Limited Warranty

Precision Digital Corporation warrants this product against defects in material or workmanship for the specified period under “Specifications” from the date of shipment from the factory. Precision Digital’s liability under this limited warranty shall not exceed the purchase value, repair, or replacement of the defective unit.

## Registered Trademarks

Modbus® is a registered trademark of Schneider Electric. All other trademarks mentioned in this document are the property of their respective owners.

© 2016 Precision Digital Corporation. All rights reserved.

**[www.predig.com](http://www.predig.com)**

## Table of Contents

Table of Contents .....	3	Signal Connector .....	9
Table of Figures .....	3	4-20 mA Output Connector.....	9
Introduction .....	4	Digital I/O Connector .....	10
Ordering Information .....	4	Modbus RTU Serial Communications.....	10
Specifications .....	5	Setup and Programming .....	11
General .....	5	Overview.....	11
Analog Input .....	5	Programming Buttons.....	12
Isolated 4-20 mA Transmitter Output .....	5	Quick Tip .....	12
Digital Input / Output Terminal.....	5	PDW Manager Software.....	13
RS485 Modbus® RTU Serial Comms .....	6	Display Functions & Messages .....	14
PDW Manager Software.....	6	Primary Unit .....	14
Safety Information .....	6	Secondary Unit .....	15
Installation .....	6	Setup Menu .....	16
Unpacking.....	6	Entering Numeric Values .....	16
Pre-Installed Conduit Plug.....	7	Primary Device Menus.....	17
Mounting Instructions .....	7	Secondary Device Menus.....	20
Cover Jam Screw .....	7	Display Signal I/O and Digital I/O Status .....	20
FCC Notice .....	7	Programming with PDW Manager.....	21
IMPORTANT .....	7	Troubleshooting .....	24
Canada (IC) Notice .....	7	Factory Defaults & User Settings .....	27
Connections.....	8	Mounting Dimensions.....	28
Power Connector .....	9		

## Table of Figures

Figure 1. PDW30 Device Assembly, Rear View .....	8	Figure 7. Multiple Device RS485 Modbus	
Figure 2. Power Connections.....	9	Connection .....	10
Figure 3. Analog Input Connections.....	9	Figure 8. Enclosure Dimensions – Front View.....	28
Figure 4. 4-20 mA Output Connections .....	9	Figure 9. Enclosure Dimensions – Side Cross	
Figure 5. Digital I/O Connections .....	10	Section View .....	28
Figure 6. Three- and Five-Wire RS485 Modbus			
Connections .....	10		

## Introduction

The Precision Digital PDW30 gives you a simple, straightforward way to get an analog, discrete, or Modbus® signal from where you have it to where you need it. It's a point-to-point wireless bridge packaged in a rugged, weather tight housing designed to meet the demands of industrial installations.

The PDW30 is simple to order, simple to configure, and easy to trust with your application. Guaranteed ranges assure it will work with your application, or you can send it back - no questions asked. A wireless survey tool is available for those who may require a site survey for longer distances, making it easy to verify the installation will work the first time.

The PDW30 takes an analog, discrete, or Modbus® input and wirelessly broadcasts it to a second PDW30 unit. The secondary unit then recreates that signal at its location. The secondary unit may also transmit it's own analog, discrete, or Modbus signals back to the primary unit. Just put the units in the field anywhere you have a signal and power.

A wide range of accessories, including mounting kits, antenna-related accessories, and repeaters, are available. The antenna may be directly attached or remotely located. High gain directional antennae are also offered.

## Ordering Information

### Standard Model

Model	Description
PDW30-SNA	PDW30 Point-to-Point Wireless Bridge

### Accessories

Model	Description
PDA10	PDW Wireless Signal Strength Survey Tool
PDW30-RNA	PDW30 Repeater Kit (Two Modules with Two Antennae)
PDA3120-N	RP-SMA F to N Male Antenna Cable 20ft
PDA3140-N	RP-SMA F to N Male Antenna Cable 40ft
PDA3120-S	RP-SMA M/F Antenna Cable 20ft
PDA3140-S	RP-SMA M/F Antenna Cable 40ft
PDA3900-12-N	PDW 900 MHz Antenna, 1/2" NPT
PDA3900-6Y-N	Yagi Antenna 6dB
PDA3900-9Y-N	Yagi Antenna 9dB
PDA6963	Stainless Steel PDW30 Mounting Kit

## Specifications

Except where noted all specifications apply to operation at +25°C.

### General

<b>Display</b>	32-character dual-line alphanumeric dot matrix LCD display with back-light (4.68mm x 2.21mm characters)
<b>Display Orientation</b>	Display may be mounted at 180° from default orientation
<b>Network ID</b>	Field selectable: 0 - 99
<b>Programming Methods</b>	Four programming buttons (behind glass) or PC with PDW Manager software.
<b>Recalibration</b>	All ranges are calibrated at the factory. Recalibration is recommended at least every 12 months.
<b>Process/ Digital I/O Display</b>	Press the <i>display</i> button once to display the present analog input and output. Press the <i>display</i> button again to display digital I/O states.
<b>Password</b>	A programmable password restricts modification of program settings.
<b>Power</b>	12-28 VDC, 5 W max
<b>Non-Volatile Memory</b>	All programmed settings are stored in non-volatile memory for a minimum of ten years if power is lost.
<b>Isolation</b>	500 V
<b>Environmental</b>	Operating temperature range: -40 to 65°C (display inoperable < -20 °C); Storage temperature range: -40 to 85°C; Relative humidity: 0 to 90% non-condensing
<b>Connections</b>	Removable screw terminal blocks accept 12 to 22 AWG wire.
<b>Enclosure</b>	Cast aluminum with glass window, 0.30% max copper content, corrosion resistant powder coating, color: blue. NEMA 4X/IP68. Three ½" NPT threaded conduit openings. One ½" NPT stainless steel conduit plug with 10 mm hex key fitting installed.
<b>Mounting</b>	May be mounted directly to conduit. Two mounting holes for 1.5" pipe or wall mounting. See Mounting Dimensions on page 28 for mounting space requirements.
<b>Signal Connector Tightening Torque</b>	2.2 lb-in (0.25 Nm)
<b>Shipping Dimensions</b>	17" x 14" x 9" (43.2 cm x 35.6 cm x 22.9 cm) (L x W X H)
<b>Shipping Weight</b>	5 lbs. (2.27 kg)
<b>Warranty</b>	3 years parts & labor

### Wireless Radio

<b>Frequency</b>	900 MHz
------------------	---------

<b>Range</b>	500 ft (152.4 m) indoor, 1 mi (1.61 km) outdoor (line-of-sight)
<b>Encryption</b>	AES 128-bit encryption available using PDW Manager software
<b>Interference Reduction</b>	Frequency Hopping Spread Spectrum (FHSS)
<b>Power Output</b>	24 dBm (250 mW)
<b>Sensitivity</b>	-101 dBm

### Analog Input

<b>Inputs</b>	Field selectable: 4-20 mA, 0-10 V, 0-5 V, 1-5 V						
<b>Accuracy</b>	±0.03% of calibrated span ±1 count						
<b>Temperature Drift</b>	0.005% of calibrated span/°C max from 0 to 65°C ambient, 0.01% of calibrated span/°C max from -40 to 0°C ambient						
<b>Calibration Range</b>	<table border="1"> <tr> <th>Input Range</th> <th>Min Span Input 1 &amp; 2</th> </tr> <tr> <td>4-20 mA</td> <td>0.15 mA</td> </tr> <tr> <td>±10 V</td> <td>0.01 V</td> </tr> </table> <p>An error will appear if the input 1 and input 2 signals are too close.</p>	Input Range	Min Span Input 1 & 2	4-20 mA	0.15 mA	±10 V	0.01 V
Input Range	Min Span Input 1 & 2						
4-20 mA	0.15 mA						
±10 V	0.01 V						
<b>Input Impedance</b>	Voltage ranges: greater than 500 kΩ; Current ranges: 50 - 100 Ω (depending on resettable fuse impedance)						
<b>Signal Loss</b>	Inputs will remain off (open circuit) until wireless units are reconnected.						
<b>HART Transparency</b>	Analog input will not interfere with existing HART communications on the wired 4-20 mA signal						

### Isolated 4-20 mA Transmitter Output

<b>Output Source</b>	Analog input from connected wireless unit						
<b>Calibration</b>	Factory calibrated: 4.000 to 20.000 = 4-20 mA output						
<b>Accuracy</b>	± 0.1% of span ± 0.004 mA						
<b>Temperature Drift</b>	0.4 μA/°C max from 0 to 65°C ambient, 0.8 μA/°C max from -40 to 0°C ambient <i>Note: Analog output drift is separate from input drift.</i>						
<b>Signal Loss</b>	mA output will become 3.2 mA after approx. 25 seconds						
<b>Output Loop Resistance</b>	<table border="1"> <tr> <th>Power supply</th> <th>Minimum</th> <th>Maximum</th> </tr> <tr> <td>24 VDC</td> <td>10-ohms</td> <td>900-ohms</td> </tr> </table>	Power supply	Minimum	Maximum	24 VDC	10-ohms	900-ohms
Power supply	Minimum	Maximum					
24 VDC	10-ohms	900-ohms					

### Digital Input / Output Terminal

<b>Channels</b>	Four (4) digital connections, independently field selectable as either inputs or outputs
<b>DI Logic High</b>	3 to 5 VDC
<b>DI Logic Low</b>	0 to 1.25 VDC
<b>DO Logic High</b>	3.1 to 3.3 VDC
<b>DO Logic Low</b>	0 to 0.4 VDC
<b>Source Current</b>	0.5 mA maximum output current
<b>Sink Current</b>	1.5 mA minimum input current
<b>Signal Loss</b>	Digital output goes to logic high

**RS485 Modbus® RTU Serial Comms**

<b>Compatibility</b>	EIA-485
<b>Connectors</b>	Removable screw terminal connector
<b>Max Distance</b>	3,937' (1,200 m) max
<b>Baud Rate</b>	1200 – 57,600 bps
<b>Transmit Time Delay</b>	Programmable between 0 and 199 ms
<b>Data</b>	8 bit (1 start bit, 1 or 2 stop bits)
<b>Parity</b>	Even, Odd, or None with 1 or 2 stop bits

<b>Byte-To-Byte Timeout</b>	0.01 – 2.54 second
<b>Turn Around Delay</b>	Less than 2 ms (fixed)

**PDW Manager Software**

<b>System Requirements</b>	Microsoft® Windows® XP/Vista/7/8/10
<b>Communications</b>	USB 2.0 (Standard USB A to Micro USB B)
<b>Configuration</b>	Configure devices one at a time

**Safety Information**

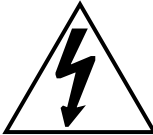
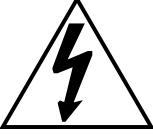
 <p><b>Caution:</b> <i>Read complete instructions prior to installation and operation of the meter.</i></p>	 <p><b>Warning:</b> <i>Read all product labels completely and follow all instructions and requirements listed on the labels for installation or service.</i></p>
 <p><b>Warning!</b></p>	<p><b>Installation and service should be performed only by trained service personnel. Service requiring replacement of internal components must be performed at the factory.</b></p>

**Installation**

All pushbuttons and wiring connectors are accessed by opening the enclosure. To access electrical connectors, remove the 2 captive screws and remove the meter assembly. Pushbuttons may also be accessed using the magnet assembly if reed switches are installed.

**Unpacking**

Remove both units from box. Inspect the packaging and contents for damage. Report damages, if any, to the carrier. If any part is missing or the units malfunction, please contact your supplier or the factory for assistance.

## Pre-Installed Conduit Plug

The PDW30 is supplied with one pre-installed optional conduit plug for installations that do not require the use of both conduit entries. The conduit plug includes an internal hexagonal socket recess for removal.

## Mounting Instructions

The PDW30 has two mounting holes that may be used for a 1.5" pipe mounting or wall mounting. Alternatively, the unit may be supported by the conduit using the conduit holes provided. The antenna is threaded into one of the three conduit holes and may be moved as appropriate for the installation.

It can also be mounted by using the PDA6963 mounting bracket in order to orient the device antenna away from the pipe. Refer to Mounting Dimensions on page 28 for details on wall or panel space requirements.

## Cover Jam Screw

The cover jam screw should be properly installed once the meter has been wired and tested in a safe environment. The cover jam screw is intended to prevent the removal of the meter cover in a flameproof environment without the use of tools. Using a M2 hex wrench, turn the screw clockwise until the screw contacts the meter. Turn the screw an additional 1/4 to 1/2 turn to secure the cover.

**Caution:** Excess torque may damage the threads and/or wrench.

## FCC Notice

Contains FCC ID: MCQ-XB900HP

The enclosed device complies with Part 15 of the FCC Rules. Operation is subject to the following two conditions: (i.) this device may not cause harmful interference and (ii.) this device must accept any interference received, including interference that may cause undesired operation.

## IMPORTANT

The RF module has been certified for remote and base radio applications. If the module will be used for portable applications, the device must undergo SAR testing. This equipment has been tested and found to comply with the limits for a Class B digital device, pursuant to Part 15 of the FCC Rules. These limits are designed to provide reasonable protection against harmful interference in a residential installation. This equipment generates, uses and can radiate radio frequency energy and, if not installed and used in accordance with the instructions, may cause harmful interference to radio communications. However, there is no guarantee that interference will not occur in a particular installation.

If this equipment does cause harmful interference to radio or television reception, which can be determined by turning the equipment off and on, the user is encouraged to try to correct the interference by one or more of the following measures: Re-orient or relocate the receiving antenna, Increase the separation between the equipment and receiver. Connect equipment and receiver to outlets on different circuits, or consult the dealer or an experienced radio/TV technician for help.

## Canada (IC) Notice

Contains Model: XB900HP, IC: 1846A-XB900HP

Integrator is responsible for its product to comply with IC ICES-003 & FCC Part 15, Sub. B - Unintentional Radiators. ICES-003 is the same as FCC Part 15 Sub. B and Industry Canada accepts FCC test report or CISPR 22 test report for compliance with ICES-003.

## Connections

To access the connectors, remove the enclosure cover and unscrew the two captive stainless steel screws. Remove the electronics assembly from the enclosure. Signal connections are made to removable terminal blocks on the back of the electronics assembly. Grounding connections are made to the two ground screws provided on the base – one internal and one external.

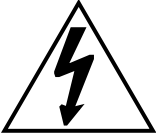

**Warning!**

- **Static electricity can damage sensitive components.**
- **Observe safe handling precautions for static-sensitive components.**
- **Use proper grounding procedures/codes.**
- **Observe all safety regulations. Electrical wiring should be performed in accordance with all agency requirements and applicable national, state, and local codes to prevent damage to the meter and ensure personnel safety.**

Figure 1 below shows the locations of screw terminal blocks on the rear of the wireless unit assembly.

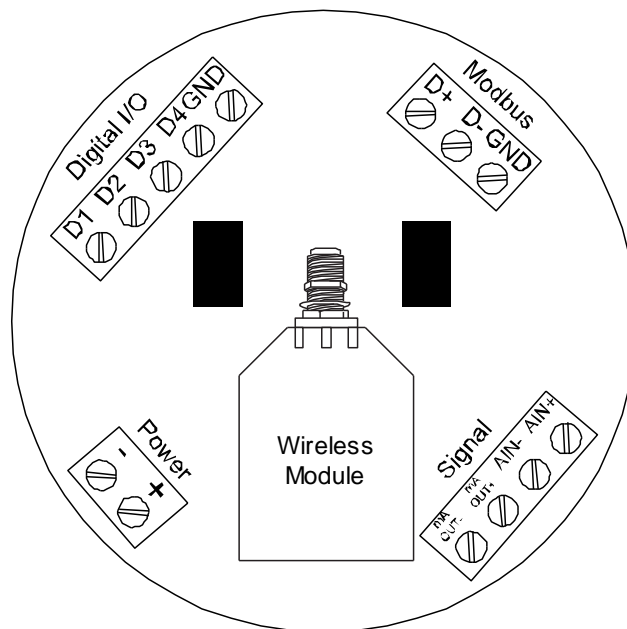

**Figure 1. PDW30 Device Assembly, Rear View**



### Power Connector

Power connections are made to a two-terminal connector labeled POWER in Figure 1. The meter will operate regardless of DC polarity connection. The + and - symbols are only a suggested wiring convention.

Make sure that the power supply can provide between 12 and 28 VDC to the wireless device.

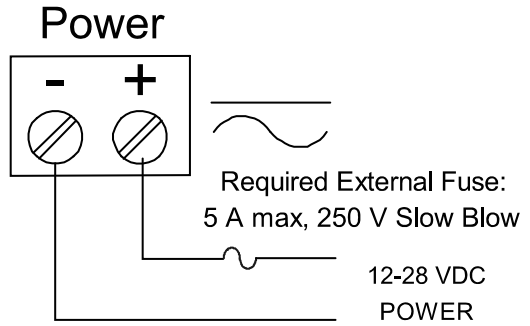

Figure 2. Power Connections

### Signal Connector

The analog input may be either 4-20 mA, 0-10 V, 0-5 V, or 1-5 V. The appropriate input type must be programmed for each unit.

Once the appropriate input type has been programmed, wire the analog signal source to the device as shown in the diagram at right.

The analog input will not interfere with any existing HART signal on a 4-20 mA current loop. However, this signal **will not** be transmitted wirelessly.

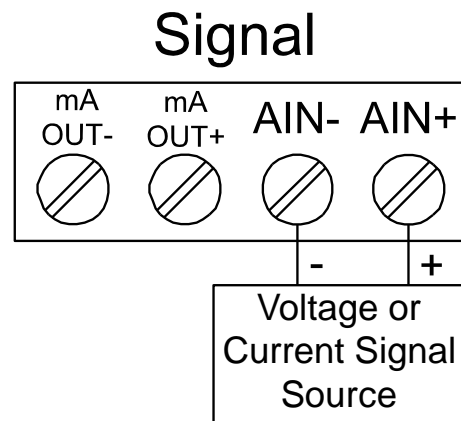

Figure 3. Analog Input Connections

### 4-20 mA Output Connector

The 4-20 mA output corresponds with the analog input signal on the paired wireless device. The analog output signal is always 4-20 mA, regardless of the input type on the other wireless module.

For instance, if the analog input type on the first device was 0-10 V and the input value was 5 V, the second device would output 12 mA.

Connect the mA OUT terminals to a device scaled to read a 4-20 mA signal.

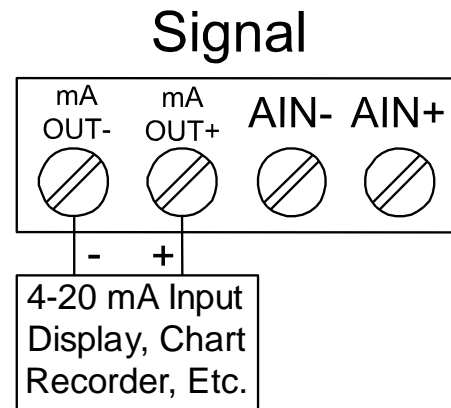

Figure 4. 4-20 mA Output Connections

### Digital I/O Connector

All digital connections are wired to ground. The primary unit digital I/O settings determine whether a digital connection receives power constantly or intermittently, thereby determining whether it is an input or an output, respectively.

**Note:** Each connection may be set independently in the device settings as either an input or an output. In the diagram to the right, D4 & D3 are digital inputs and D2 is a digital output.

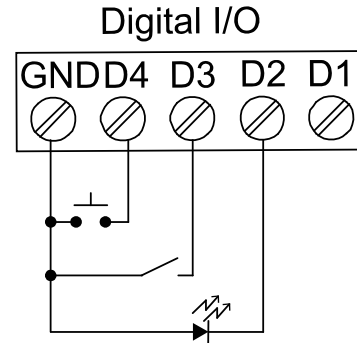

Figure 5. Digital I/O Connections

### Modbus RTU Serial Communications

The PDW30 acts as a simple pass-through for Modbus communications. As such, multiple Modbus enabled devices may transmit wirelessly using the PDW30 Wireless Bridge.

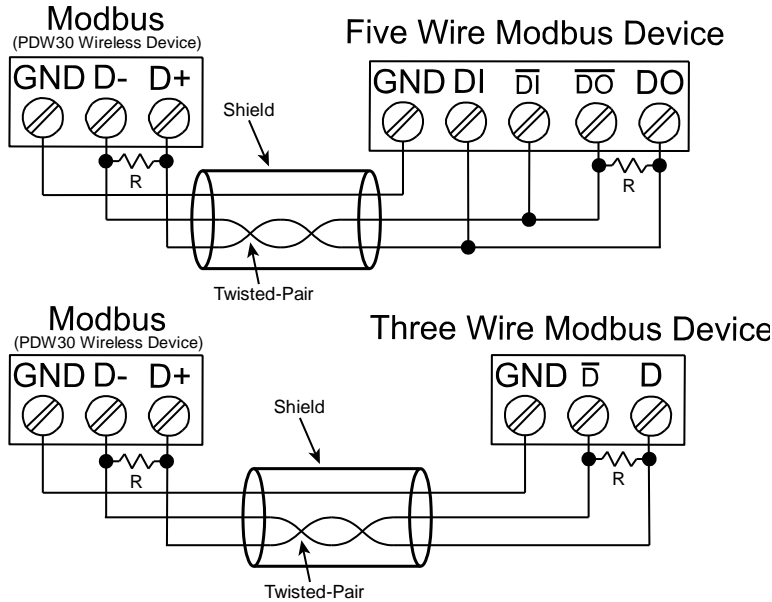

Figure 6. Three- and Five-Wire RS485 Modbus Connections

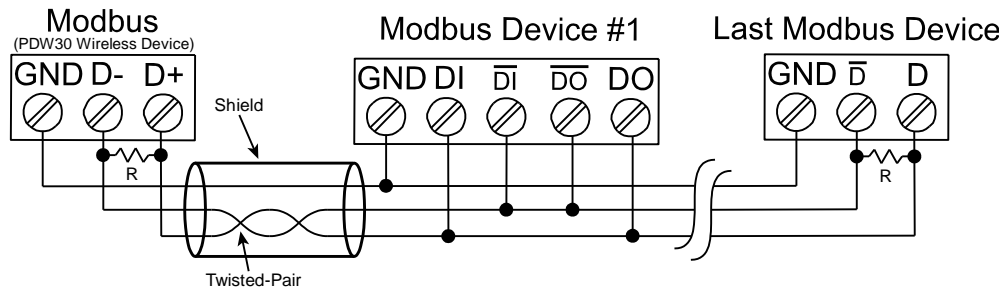

Figure 7. Multiple Device RS485 Modbus Connection

**Notes:**

1. Termination resistors are optional and values depend on the cable length and characteristic impedance. Consult the cable manufacturer for recommendations.
2. Use shielded cable, twisted-pairs plus ground. Connect ground shield only at one location.

## Setup and Programming

*The units are factory calibrated prior to shipment to read in milliamps and volts depending on the input selection. The calibration equipment is certified to NIST standards.*

### Overview

There are no jumpers to set for wireless device input selection.

Setup and programming is done through the programming buttons located underneath the enclosure cover. After power and input signal connections have been completed and verified, apply power to the device.

### Primary



### Secondary







## Programming Buttons

The units can be programmed using the buttons located behind the enclosure cover. Use the *menu* button to enter or exit *programming mode*, the *next* button to cycle forward through menu options, the *previous* button to cycle backward through menu options, and the *enter* button to select the menu item or option you want.

During number entry, use the *next* button to select a digit and the *previous* button to increment the selected digit.

Press the *display* button while in *run mode* to show the current analog and digital inputs and outputs.

Button	Description	Display	Status
 <b>MENU</b>	<b>Menu</b> Enter or exit the device menu	RSSI	<b>Received Signal Strength Indicator</b> Indicates the wireless signal strength between wireless devices on a scale of 1 to 10.
 <b>ENTER</b>	<b>Enter</b> Select a menu item of option	RT	<b>Receiving/Transmitting</b> Flashes while the devices are sending and/or receiving data
<b>PREV</b> 	<b>Previous</b> Cycle backward through menus or increment digit	PRI / SEC	<b>Primary/Secondary</b> Indicates whether the device is the primary unit or the secondary unit. This distinction is fixed and cannot be changed.
<b>DISP/NEXT</b> 	<b>Next</b> Cycle forward through menus or select next digit	LINK OK / CONNECTING	<b>Link Status</b> Displays whether or not the units are currently connected
	<b>Display</b> Show current inputs and outputs	AIN / AOUT	<b>Analog Input/Analog Output</b> Labels for the current analog input and analog output (Shown when the <i>display</i> button is pressed)
		DI / DO	<b>Digital Input/Digital Output</b> Labels for each of the current digital inputs or outputs (Shown when the <i>display</i> button is pressed twice)

### Quick Tip

While programming the wireless units, it may be useful to view the current signal or digital I/O in order to ensure that the correct signals are reaching the units. Pressing either the *previous* or *display* buttons while the device is in run mode will cycle through the unit's display modes which are, in order, *link status*, *analog I/O*, and *digital I/O*.

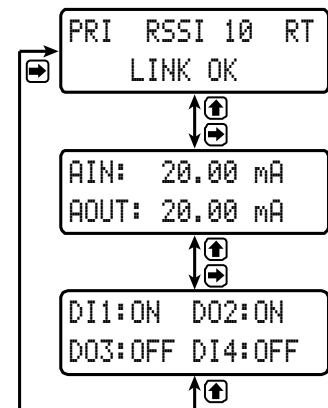

## PDW Manager Software

The units can also be programmed using the PC based *PDW Manager*. Units connect to a PC via the micro USB connection on their face, underneath the enclosure cover.

Use of PDW Manager is required for programming advanced settings, such as wireless encryption, and analog signal calibration.

**Note:** *Units must be powered externally prior to programming via USB.*

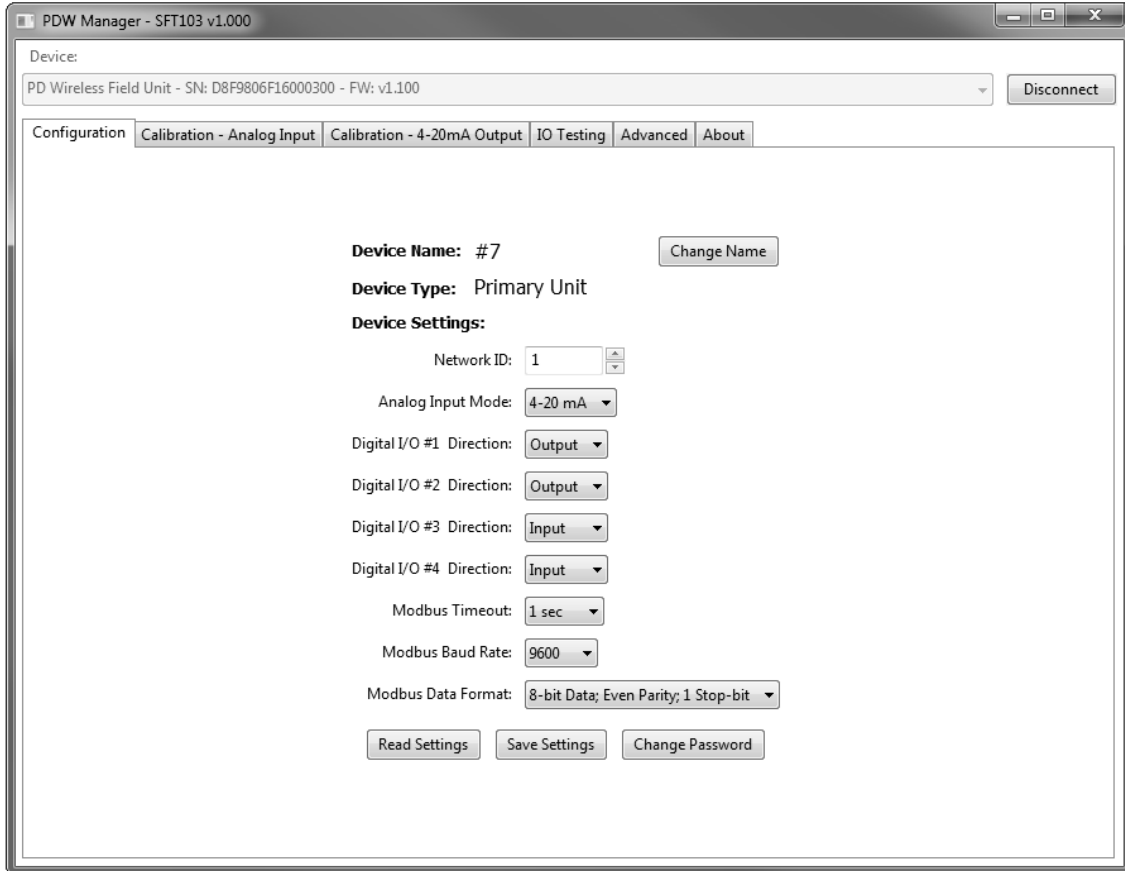

PDW Manager is available on the included CD or online at [www.predig.com/PDWManager](http://www.predig.com/PDWManager).

Instructions on the use of PDW Manager to program the PDW30 wireless units can be found under Programming with PDW Manager on page 21.

## Display Functions & Messages

Shown below is a list of all display messages in each device's setup menu. This list is in order of appearance when pressing the *next* button. An indented line indicates a sub-menu or item.

### Primary Unit

Display	Action/Setting Description
ANALOG INPUT SETUP	Change the analog input type
ANALOG INPUT	Displays the current analog input type (press <i>enter</i> to change)
4-20mA	Set the analog input to 4-20 mA
0-10V	Set the analog input to 0-10 V
0-5V	Set the analog input to 0-5 V
1-5V	Set the analog input to 1-5 V
BACK TO SETUP MENU	Return to the setup menu
DIGITAL I/O SETUP	Change whether each digital connection is an input or an output
DIGITAL I/O #1	Displays digital connection #1's current setting (press <i>enter</i> to change)
INPUT	Set the selected digital connection to input
OUTPUT	Set the selected digital connection to output
DIGITAL I/O #2	Displays digital connection #2's current setting (press <i>enter</i> to change)
DIGITAL I/O #3	Displays digital connection #3's current setting (press <i>enter</i> to change)
DIGITAL I/O #4	Displays digital connection #4's current setting (press <i>enter</i> to change)
BACK TO SETUP MENU	Return to the setup menu
NETWORK AND MODBUS SETUP	Change settings related to wireless network and Modbus® input
NETWORK ID	Displays the point-to-point wireless network ID (press <i>enter</i> to change)
01-99	The network ID can be any number between 01 and 99
MODBUS TIMEOUT	Displays the Modbus timeout setting (press <i>enter</i> to change)
1 SEC	1 second timeout
2 SEC	2 second timeout
3 SEC	3 second timeout
4 SEC	4 second timeout
5 SEC	5 second timeout
0.5 SEC	0.5 second timeout
MODBUS BAUD RATE	Displays the Modbus baud rate setting (press <i>enter</i> to change)
9.6K	9.6 K baud rate
19.2k	19.2 K baud rate
28.8k	28.8 K baud rate
38.4k	38.4 K baud rate
57.6k	57.6 K baud rate
1.2k	1.2 K baud rate
2.4k	2.4 K baud rate
4.8k	4.8 K baud rate

Display	Action/Setting Description
DATA FORMAT	Displays the Modbus data format setting (press <i>enter</i> to change)
8E1	Data format 8E1
8O1	Data format 8O1
8N2	Data format 8N2
BACK TO SETUP MENU	Return to the setup menu
PASSWORD SETUP	Change the device password
PASSWORD (0=OFF)	Displays the current device password (press <i>enter</i> to change)
0000-9999	Password can be any number from 0001 to 9999 (0000 disables)
BACK TO SETUP MENU	Return to the setup menu
RESTORE DEFAULTS	Restore the unit to factory default settings
LOAD DEFAULTS?	Factory restoration confirmation prompt
NO	No, do not restore the device to factory defaults (press <i>enter</i> )
YES	Yes. restore the device to factory defaults (press <i>enter</i> )

## Secondary Unit

Display	Action/Setting Description
NETWORK ID	Displays the point-to-point wireless network ID (press <i>enter</i> to change)
01-99	The network ID can be any number between 01 and 99
ANALOG INPUT	Displays the current analog input type (press <i>enter</i> to change)
4-20mA	Set the analog input to 4-20 mA
0-10V	Set the analog input to 0-10 V
0-5V	Set the analog input to 0-5 V
1-5V	Set the analog input to 1-5 V
MODBUS TIMEOUT	Displays the Modbus timeout setting (press <i>enter</i> to change)
0.2 SEC	0.2 second timeout
0.5 SEC	0.5 second timeout
1 SEC	1 second timeout
0.1 SEC	0.1 second timeout
PASSWORD SETUP	Change the device password
PASSWORD (0=OFF)	Displays the current device password (press <i>enter</i> to change)
0000-9999	Password can be any number from 0001 to 9999 (0000 to disable)
BACK TO SETUP MENU	Return to the setup menu
RESTORE DEFAULTS	Restore the unit to factory default settings
LOAD DEFAULTS?	Factory restoration confirmation prompt
NO	No, do not restore the device to factory defaults (press <i>enter</i> )
YES	Yes. restore the device to factory defaults (press <i>enter</i> )

## Setup Menu

The setup menu consists of analog, digital (discrete), and Modbus® input/output settings, network ID, password, and factory defaults restoration.

The *primary* wireless unit determines network protocol and digital I/O settings for the *secondary* unit, simplifying the setup process. For instance, if a digital connection is programmed to be an **input** on the *primary* unit, that same connection will be an **output** on the *secondary* unit. Because of this, the *secondary* wireless unit has fewer menu options than the *primary* unit.

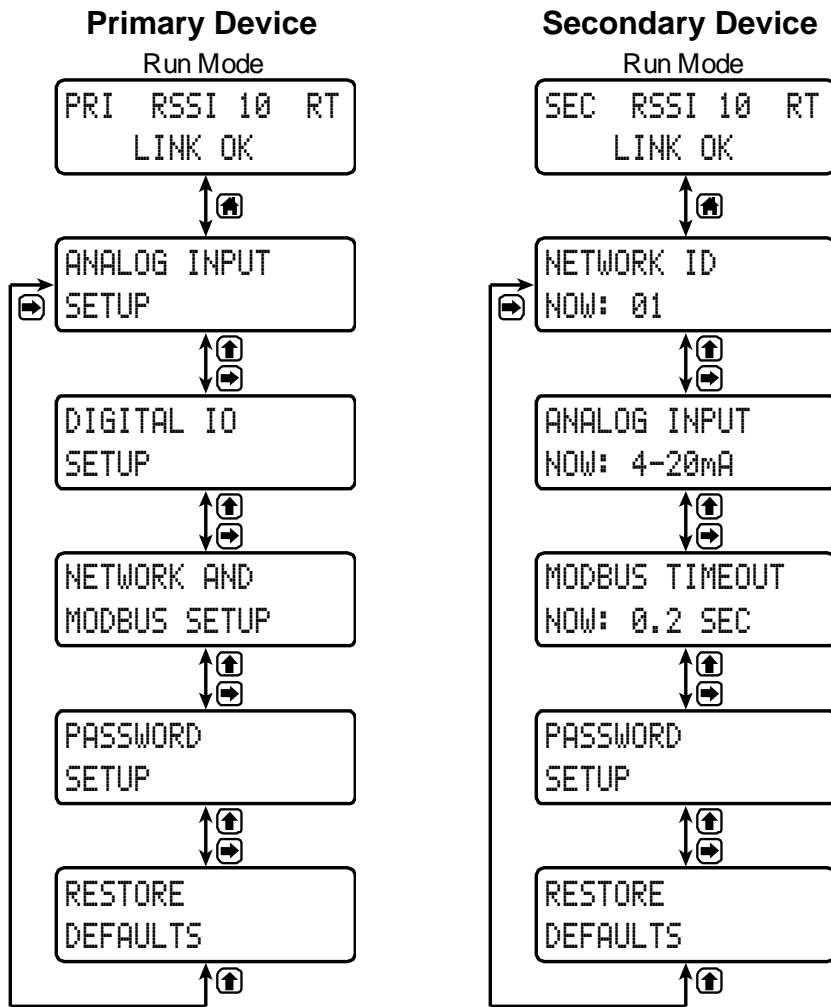

### Entering Numeric Values

Numeric values are set using the *next* and *previous* buttons. Press *next* to select next digit and *previous* to increment digit value.

The selected digit will flash.

Press the *enter* button, at any time, to accept the value or the *menu* button to exit without saving.

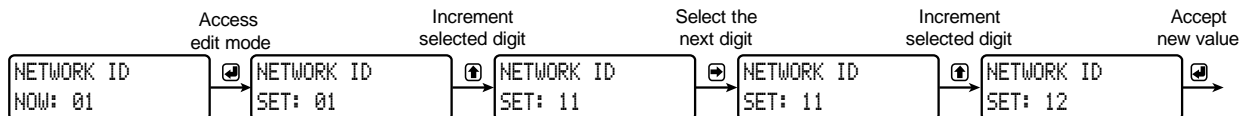



## Primary Device Menus

### Analog Input Setup

Enter the *Analog Input* menu to set up the wireless unit to accept either a current or a voltage input. The current input is capable of accepting a signal from 4 to 20 mA. The voltage input is capable of accepting a 0 to 10 VDC signal, 0 to 5 VDC signal, or 1-5 VDC signal.

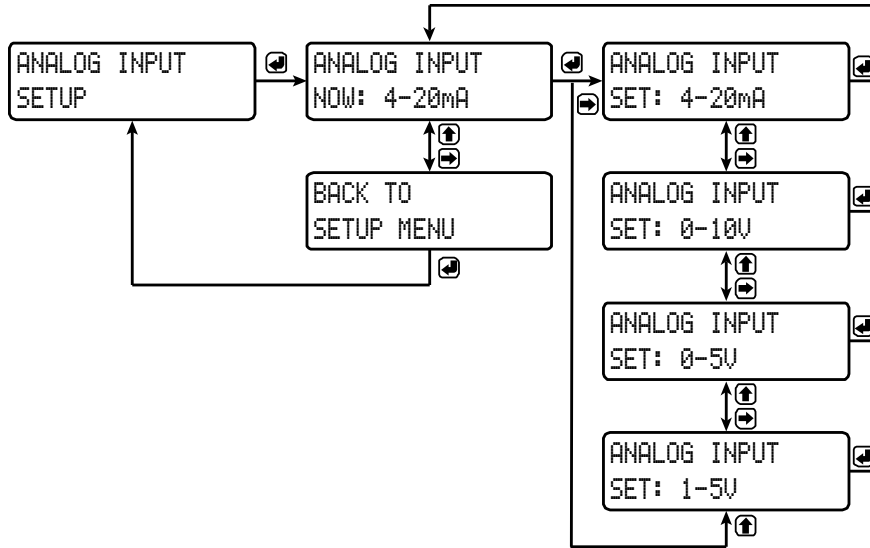

### Digital I/O Setup

All four digital connections may be set as either inputs or outputs. The setting on the primary unit determines the corresponding digital connection on the secondary unit. For instance, if digital connection number one is set as an input on the primary unit, it will be an output on the secondary unit. Each digital connection may be set independently as either an input or output.

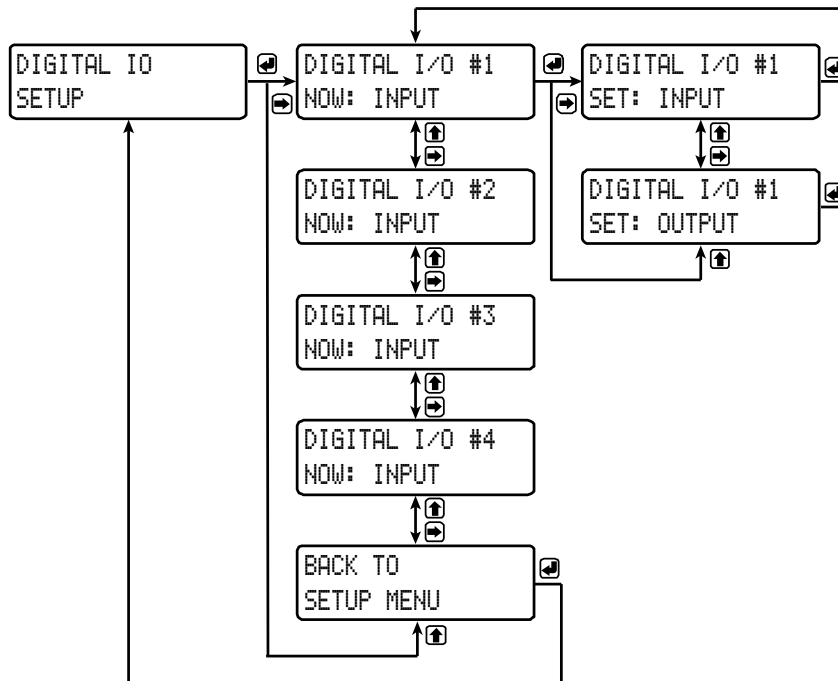

### Network and Modbus Setup

The *Network and Modbus Setup* menu is where the wireless device's *Network ID* is set and Modbus® serial communications settings are programmed.

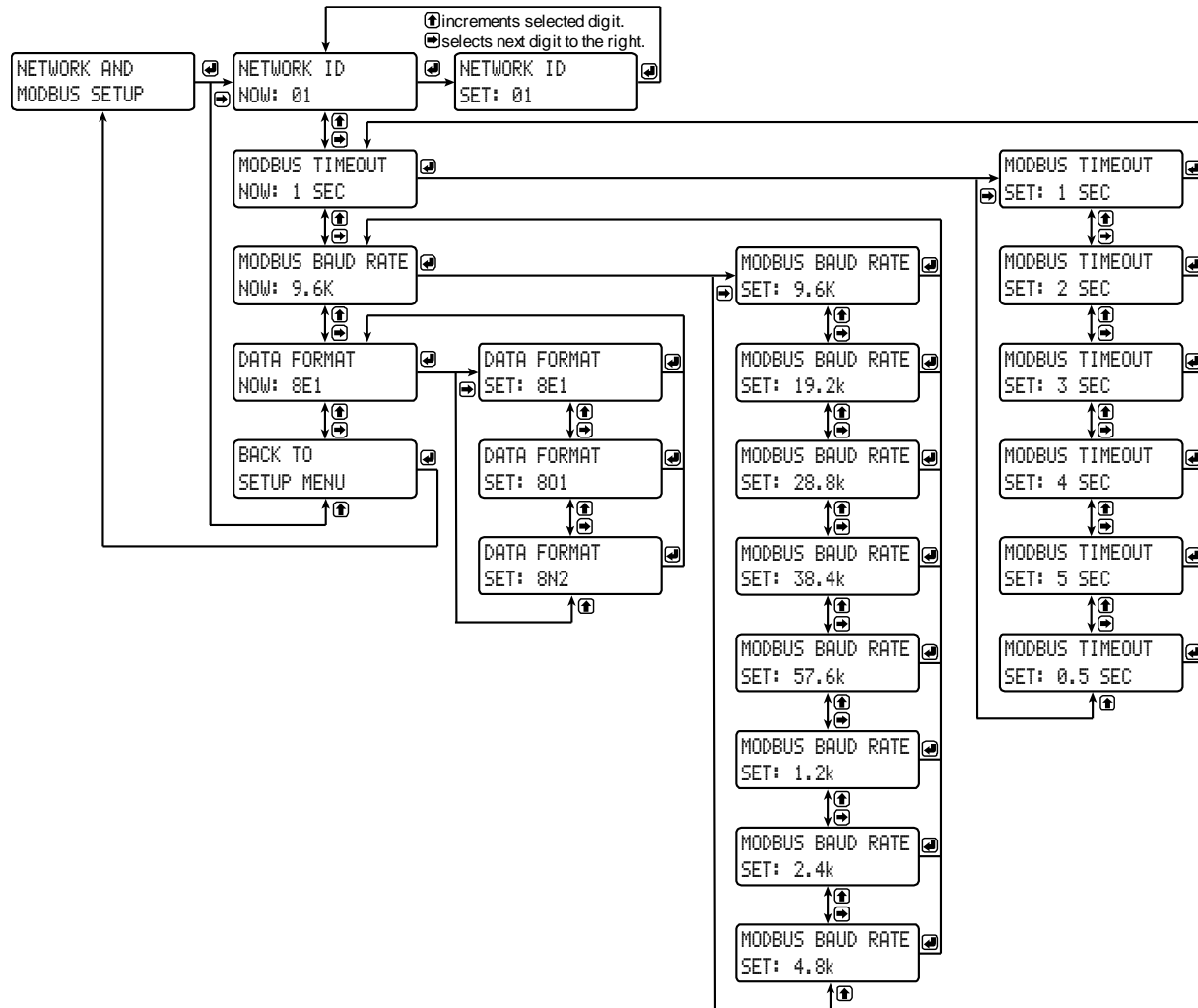

#### Network ID

The network ID determines *primary* and *secondary* wireless pairs. The primary and secondary units must share the same unique network ID in order to communicate.

#### Modbus Timeout

The Modbus timeout sets the length of time the wireless devices will wait for a reply from the other Modbus device before returning an error. This should be 1 to 2 seconds at 9600 bps on the primary device.

#### Modbus Baud Rate

The baud rate of the wireless devices must match the baud rate of the Modbus network in order to prevent collisions on the bus. The baud rate may be set between 1,200 and 57,600 bps.

#### Data Format

The data format of the wireless devices must match the data format of the Modbus network. Set the data format to either 8E1 (8-bit, even parity, 1 stop bit), 8O1 (8-bit, odd parity, 1 stop bit), or 8N2 (8-bit, no parity, 2 stop bits).

### Password Setup

Both the primary and secondary wireless units may be protected with a four digit numeric password in order to prevent unauthorized tampering. When a password has been set, you will be prompted to enter that password in order to access the device menu.

To disable password protection, simply enter 0000 as the password.

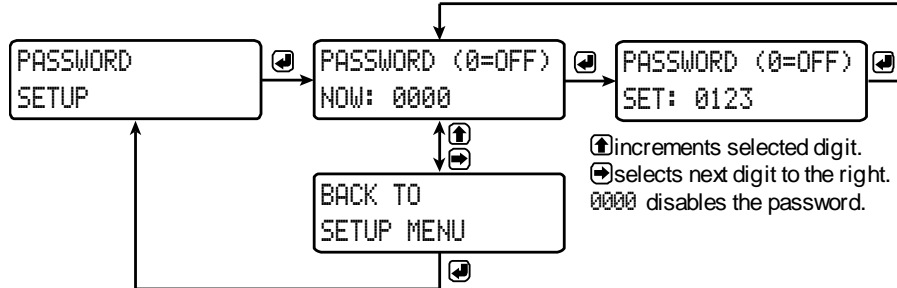

**Note:** See Entering Numeric Values on page 16 for instructions on how to enter numbers

### Making Changes to a Password Protected Meter

Once a password has been set on the device, you will be required to enter that password before being allowed to access the device menu.

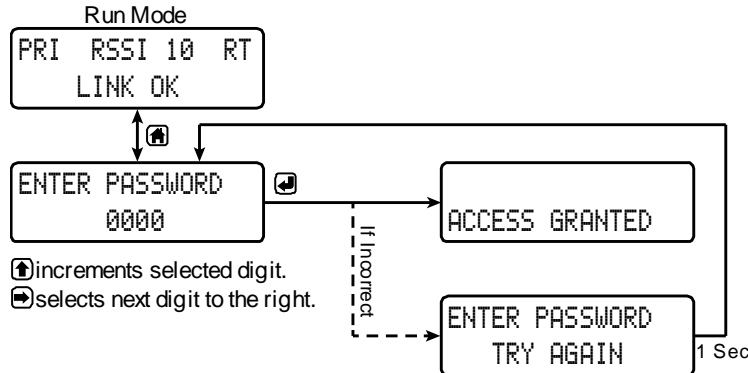

**Note:** Setting a password will require you to enter the password to access the device settings via the PC software as well.

Did you forget the password?  
 Connect the device into a PC running PDW Manager and select reset all device parameters to factory defaults.

### Restore Defaults

If a mistake has been made while programming the primary or secondary device, and it is unclear where the error occurred, the best option may be to perform a factory reset of the device and begin again.

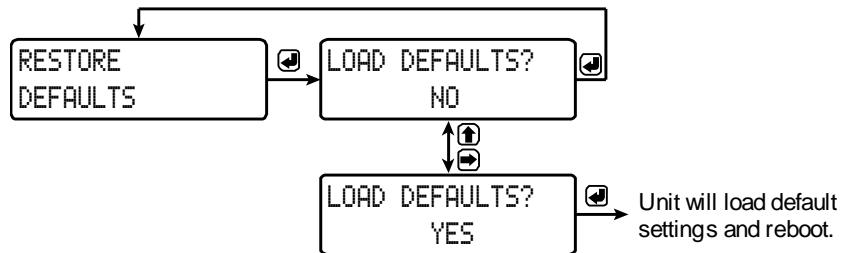

## Secondary Device Menus

The secondary device has less menu options than the primary device, shown below.

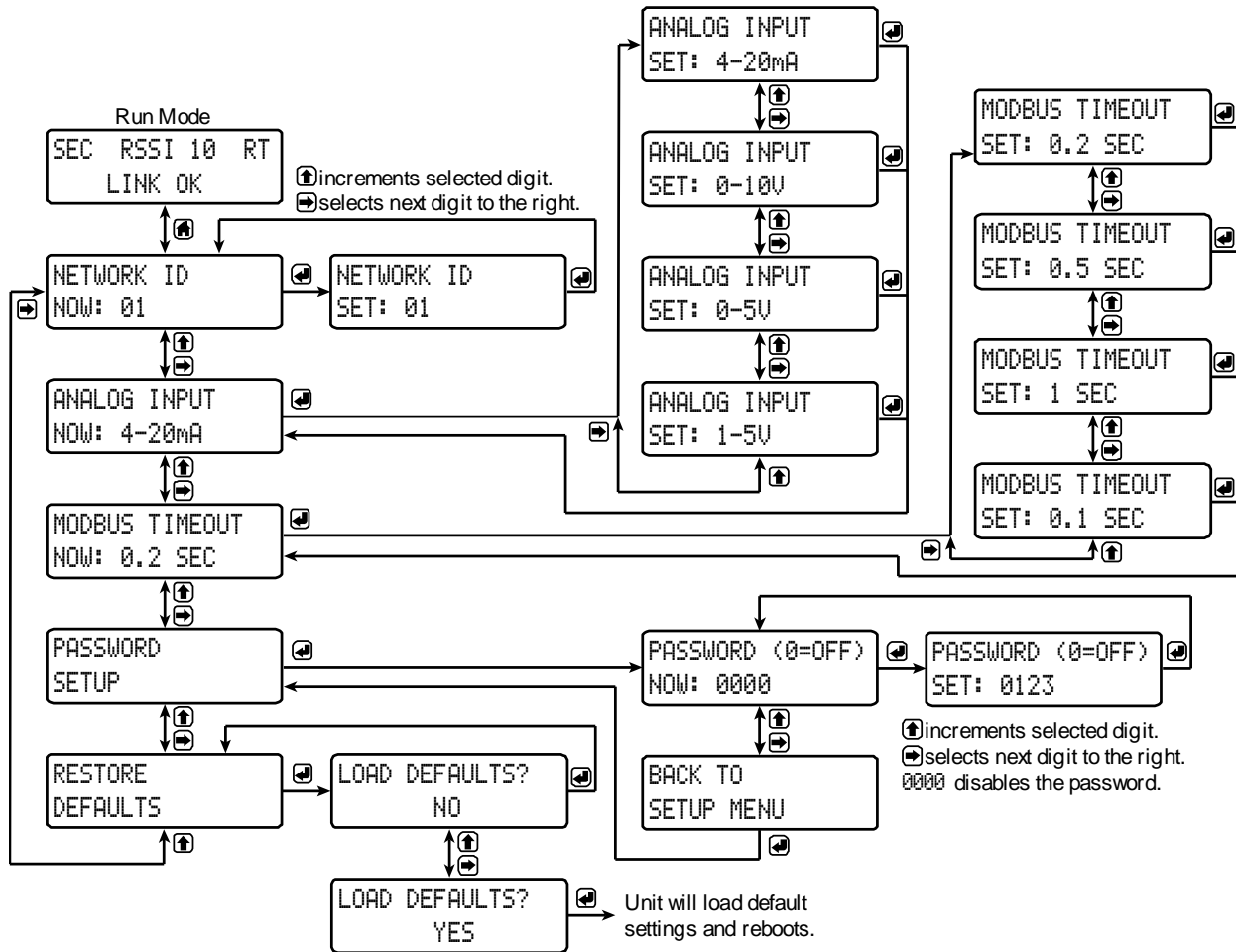

## Display Signal I/O and Digital I/O Status

Pressing either the *previous* or *display* buttons while the device is in run mode will cycle through the display modes. These modes are, in order, *link status*, *analog I/O*, and *digital I/O*.

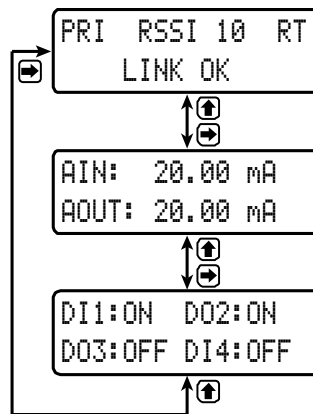

## Programming with PDW Manager

PDW Manager allows you to program the PDW30 wireless units from a PC with a USB connection. Units connect to a PC via the micro USB connection on their face, underneath the enclosure cover. Use of PDW Manager is required for programming advanced settings such as wireless encryption and analog signal calibration.

PDW Manager can be found on the included CD or downloaded from [www.predig.com/PDWManager](http://www.predig.com/PDWManager). Once the software is running, power the unit using a 12/24 VDC power supply and connect the device to the PC using the provided USB cable.

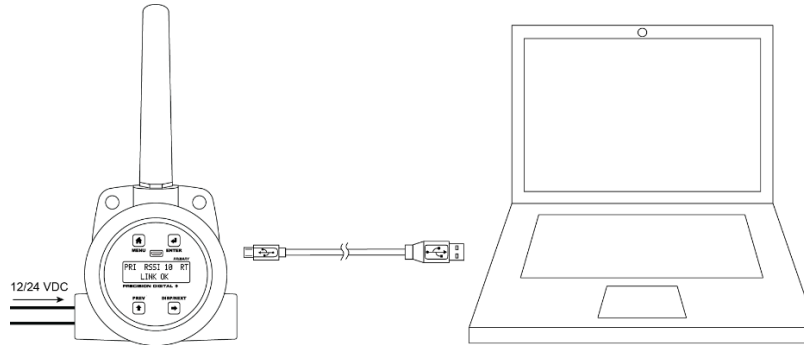

The PC will automatically install the appropriate device drivers. Once this has completed, the device will appear in the *Device* list at the top of the PDW Manager window. Click *Connect*.

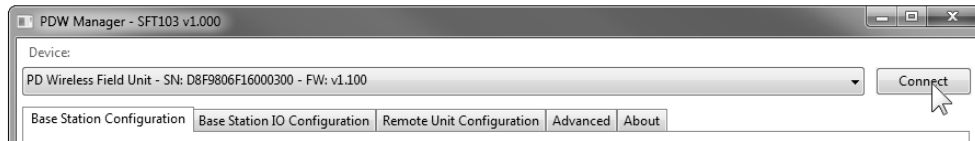

The menu options displayed will vary depending on what type of unit is connected. The PDW30 *primary* unit will have more options than the *secondary* unit. The image below shows the available options on the configuration tab while the *primary* unit is connected.

The screenshot shows the PDW Manager - SFT103 v1.000 window with the 'Configuration' tab selected. The 'Device' dropdown is set to 'PD Wireless Field Unit - SN: D8F9806F16000300 - FW: v1.100'. The 'Device Name' is '#7'. The 'Device Type' is 'Primary Unit'. The 'Device Settings' section includes: 'Network ID: 1', 'Analog Input Mode: 4-20 mA', 'Digital I/O #1 Direction: Output', 'Digital I/O #2 Direction: Output', 'Digital I/O #3 Direction: Input', 'Digital I/O #4 Direction: Input', 'Modbus Timeout: 1 sec', 'Modbus Baud Rate: 9600', and 'Modbus Data Format: 8-bit Data; Even Parity; 1 Stop-bit'. There are buttons for 'Read Settings', 'Save Settings', and 'Change Password'. A 'Disconnect' button is also visible.

**Device Name**  
Click Change Name to enter a new human readable name for the wireless device.

**Network ID**  
Enter a unique network ID for each PDW30 device pair (primary and secondary).

**Analog Input Mode**  
Select what type of analog input the device is receiving. (4-20mA, 0-10 V, 0-5V, 1-5V)

**Digital I/O Settings**  
Select whether each digital connection on the device is receiving a digital input or a digital output.

**Modbus Settings**  
Change these settings to match those of the Modbus network with which this unit is communicating.

**Read Settings**  
Click this button to load settings from the wireless hardware and display them here. This will overwrite any changes you have made in the software.

**Save Settings**  
Click this button to write all of the changes you have made in the above fields to the wireless hardware.

**Change Password**  
Click this button to change the password needed to change device settings. Enter 0000 to disable.

**Disconnect**  
Click this button to disconnect from the PDW30 wireless unit and prepare it to be unplugged from the computer.

**Note:** The Configuration tab for the secondary device will only have options for Network ID, Analog Input Mode, and Modbus Timeout.

The devices' analog inputs and outputs can be calibrated using the Calibration tabs. The IO Testing tab allows you to perform diagnostics and testing on the units.

### Calibration – Analog Input

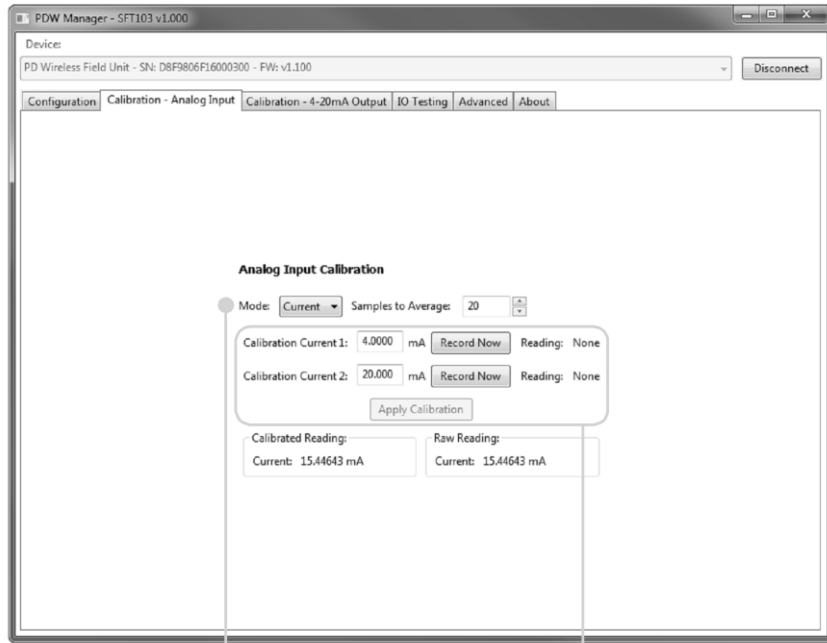

**Analog Input Calibration Mode**  
Change analog input calibration mode to either current or voltage. This will change the active analog input mode on the device and allow for calibration.

**Input Calibration**  
Record the high and low analog input range from a calibration device and apply calibration to the wireless unit.

### Calibration – 4-20mA Output

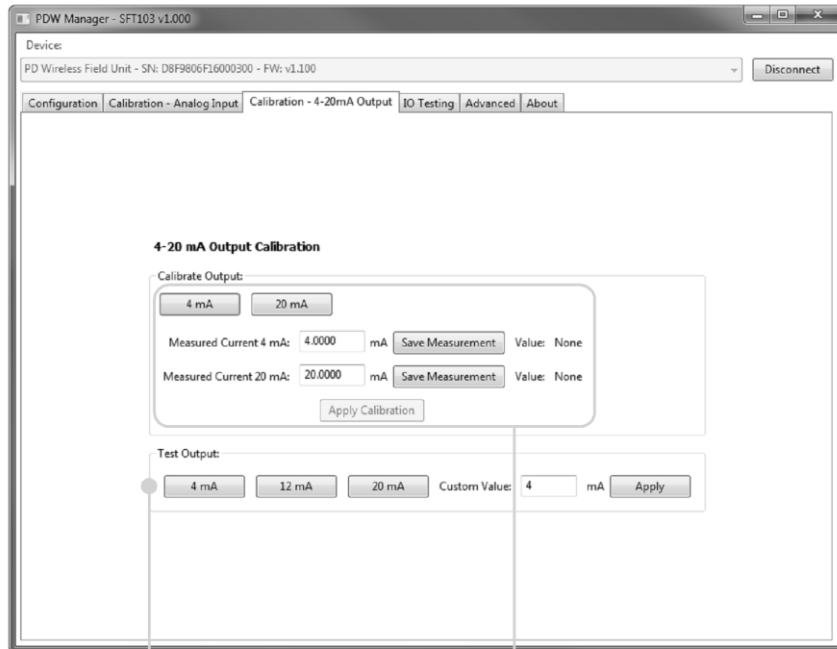

**Test 4-20 mA Output**  
Force the unit to output 4 mA, 12 mA, 20 mA, or a custom value in order to test the output and any devices that are receiving from it.

**Output Calibration**  
Record the high and low 4-20m A output range from a calibration device and apply calibration to the wireless unit.

### IO Testing

**Digital I/O Testing**  
Use the radio buttons at the top to either monitor digital I/O activity or override programmed settings in order to test I/O configuration

**Analog Input Monitoring**  
Displays the current analog input reading. Use the radio buttons to change mode.

**Output Monitoring**  
Displays the current 4-20mA analog output measurement.

**Device Logs**  
Technical information for testing and debugging purposes.

Device communication can be secured by enabling 128-bit AES encryption. A channel mask may also be set for interference immunity. The encryption key and channel mask may be entered on the *Advanced* tab.

Once you have entered the encryption information, click **Save Settings**. The wireless devices must share identical encryption keys in order to communicate, so be sure to enter the same information for the second unit.

**Channel Mask**  
Set a channel mask for interference immunity.

**AES Encryption**  
Devices can be programmed to communicate securely using 128-bit AES encryption. Enable encryption using the drop-down at the top and enter an encryption key. The two key fields must start with "0x" followed by 16 hexadecimal characters (for example: 0x46D34C5666542D06).

**Read Settings**  
Click this button to load settings from the wireless unit hardware and display them here. This will overwrite any changes you have made in the software.

**Reset to Factory Defaults**  
Click this button to permanently reset all setting on the device to their factory defaults. This will overwrite all changes you have made to the device.

**Save Settings**  
Click this button to write all of the changes you have made in the above fields to the wireless unit hardware.

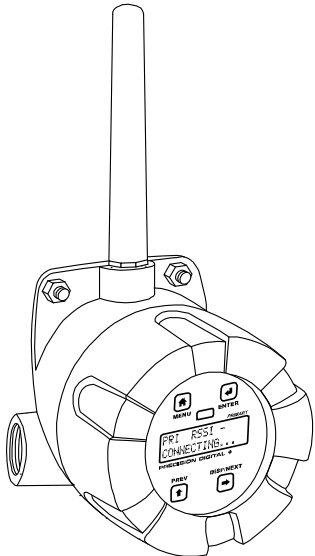
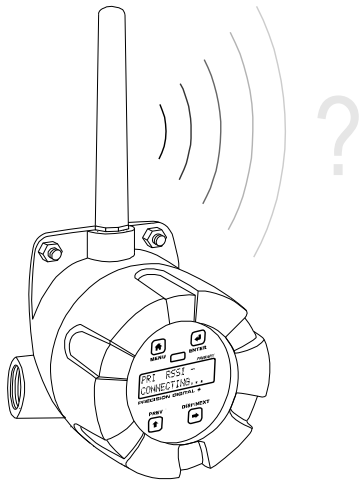

## Troubleshooting

If you are experiencing difficulties with your wireless installation, consult the troubleshooting steps listed below. For best results, identify the symptoms of the problem you are having and attempt all of the corrective actions listed for the particular symptom.

Symptom	Possible Cause	Corrective Action
<p><b>Devices will not connect.</b></p> 	Devices have mismatched network IDs.	<ul style="list-style-type: none"> <li>Devices will not connect if they do not have the same network ID. Verify that both devices share the same network ID.</li> </ul>
	Devices are out of range or there are obstacles blocking the wireless path.	<ul style="list-style-type: none"> <li>Bring devices closer together to see if it alleviates the issue. Units will display LINK OK if they are connected. If devices connect, consider placing closer together permanently, removing any obstacles, or mounting higher.</li> <li>Ensure antennas are on parallel plane. Devices that are vertically separated will not have as strong of a connection.</li> <li>If communicating over distance of miles, consider installing high gain directional antenna.</li> </ul>
	Multiple wireless devices in the area with the same ID.	<ul style="list-style-type: none"> <li>If there are multiple PDW30 wireless bridges, verify that each pair has its own unique network ID.</li> </ul>
	Encryption keys do not match	<ul style="list-style-type: none"> <li>If using encryption, ensure that the encryption keys on both devices match exactly.</li> </ul>
<p><b>Intermittent signal issues.</b></p> 	Signal is too poor.	<ul style="list-style-type: none"> <li>Check RSSI. If signal is too low, consider moving devices closer together, clearing obstacles in wireless path, or mounting devices higher.</li> <li>Ensure devices are on parallel plane.</li> <li>If communicating over distance of miles, consider installing high gain directional antenna.</li> </ul>
	Temporary obstacles are blocking the wireless path.	<ul style="list-style-type: none"> <li>Temporary obstacles, such as large trucks or heavy equipment, can interfere with wireless path. Consider moving wireless units higher or to an area with less traffic.</li> </ul>

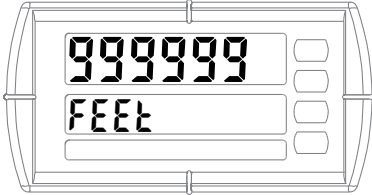
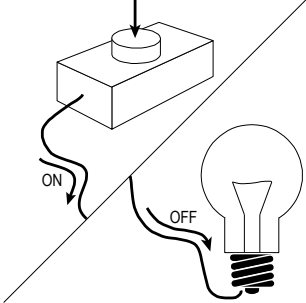
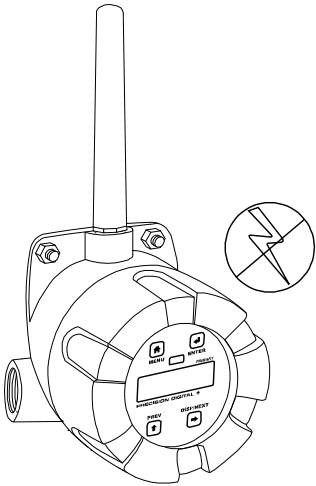

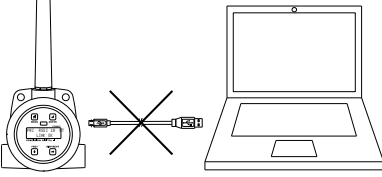
Symptom	Possible Cause	Corrective Action
<p><b>Destination device reads out of range, zero, or incorrect.</b></p> 	Wireless device has mismatched input type.	<ul style="list-style-type: none"> <li>Make sure that input type on the device is correct for the analog input being used. Options are 4-20 mA, 0-10 V, 0-5 V, or 1-5 V.</li> </ul>
	Destination device is not scaled properly.	<ul style="list-style-type: none"> <li>Destination device must accept 4-20 mA signal and be scaled to properly display the signal. Check the manufacturer's instruction manual for how to do this.</li> </ul>
	Signal connections are improperly wired.	<ul style="list-style-type: none"> <li>Double check to make sure all of the signal connections are properly wired to all devices. Check wiring diagrams starting on page 8.</li> </ul>
<p><b>Digital inputs are not corresponding with digital outputs.</b></p> 	Devices have mismatched input/output settings.	<ul style="list-style-type: none"> <li>Check to make sure the digital connection is programmed appropriately as either an input or an output.</li> </ul>
	Devices are improperly wired.	<ul style="list-style-type: none"> <li>Check to make sure all digital inputs and outputs are properly wired to all devices. Check wiring diagrams starting on page 8.</li> </ul>
<p><b>Device will not power on.</b></p> 	Not enough voltage is coming from the power supply.	<ul style="list-style-type: none"> <li>Devices require at least 12 VDC each in order to power on. Check that the power supply is providing enough voltage to the device and that there are not too many devices drawing from the supply.</li> </ul>
	Devices are improperly wired.	<ul style="list-style-type: none"> <li>Check to make sure all power connections are properly wired to all devices. Check wiring diagrams starting on page 8.</li> </ul>

Symptom	Possible Cause	Corrective Action
<p data-bbox="207 359 586 415"><b>Device will not connect to PC via USB</b></p> 	<p data-bbox="613 233 834 289">Wireless device is not powered.</p>	<ul data-bbox="857 233 1416 352" style="list-style-type: none"> <li>• The device must be powered by a 12/24 VDC power supply in order for the PC to recognize it. Power the wireless device and try again.</li> </ul>
	<p data-bbox="613 434 834 491">Software version is outdated</p>	<ul data-bbox="857 434 1416 554" style="list-style-type: none"> <li>• Check that you are running the latest software version. The latest version of PDW Manager can be downloaded at <a href="http://www.predig.com/PDWManager">www.predig.com/PDWManager</a>.</li> </ul>
	<p data-bbox="613 644 834 701">USB cable is faulty</p>	<ul data-bbox="857 644 1416 793" style="list-style-type: none"> <li>• Try connecting the wireless device using a known good micro USB cable. Any standard USB A to micro USB B cable, such as the one used to charge a smartphone, should work.</li> </ul>
<p data-bbox="321 842 472 869"><b>Other Issue</b></p> 	<p data-bbox="613 848 1416 940">If you are experiencing a symptom not listed here, or the suggested troubleshooting steps do not alleviate your problem, please contact technical support at:</p> <p data-bbox="760 982 1263 1010"><b>Phone:</b> (800) 610-5239 or (508) 655-7300</p> <p data-bbox="760 1016 1008 1043"><b>Fax:</b> (508) 655-8990</p> <p data-bbox="760 1050 1097 1077"><b>Email:</b> support@predig.com</p> <p data-bbox="760 1083 1032 1110"><b>Web:</b> www.predig.com</p>	

## Factory Defaults & User Settings

The following table shows the factory setting for most of the programmable parameters on the device. Next to the factory setting, the user may record the new setting for the particular application.

Model: \_\_\_\_\_ S/N: \_\_\_\_\_ Date: \_\_\_\_\_

### Primary

Parameter	Default Setting	User Setting
ANALOG INPUT	4-20mA	
DIGITAL I/O #1	INPUT	
DIGITAL I/O #2	INPUT	
DIGITAL I/O #3	INPUT	
DIGITAL I/O #4	INPUT	
NETWORK ID	01	
MODBUS TIMEOUT	1 SEC	
MODBUS BAUD RATE	9.6K	
DATA FORMAT	8E1	
PASSWORD	0000	

### Secondary

Parameter	Default Setting	User Setting
NETWORK ID	01	
ANALOG INPUT	4-20mA	
MODBUS TIMEOUT	0.2 SEC	
PASSWORD	0000	

## Mounting Dimensions

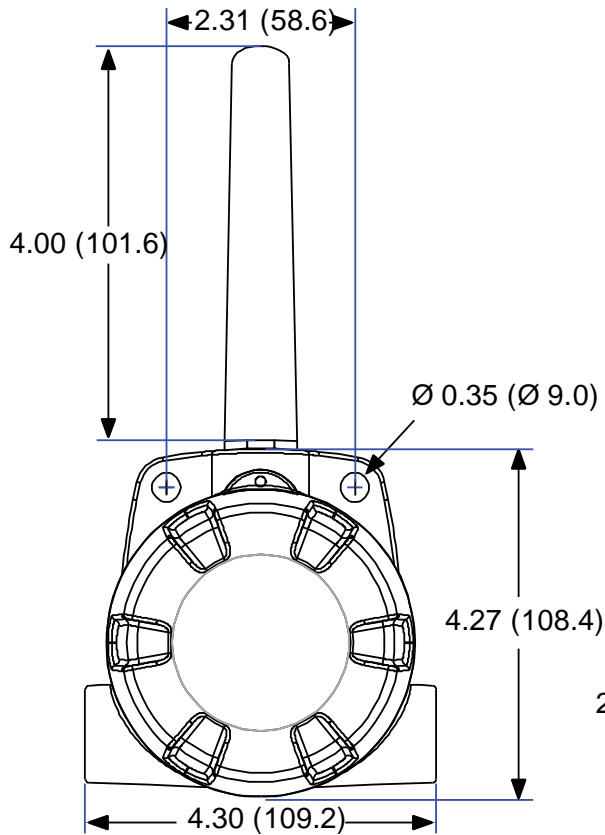

**Figure 8. Enclosure Dimensions – Front View**

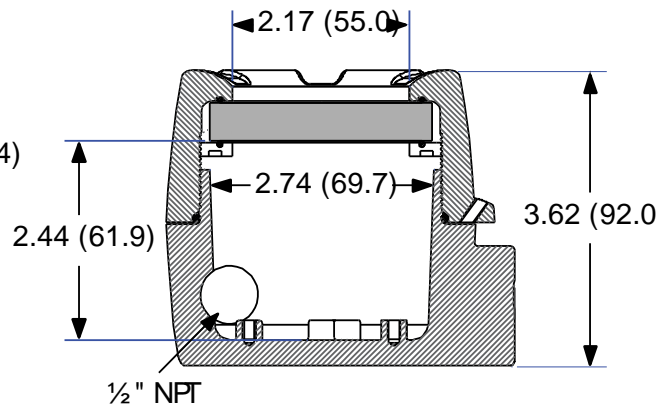

**Figure 9. Enclosure Dimensions – Side Cross Section View**

**Note:** The supplied conduit plug may extend up to 0.6 in [15 mm] from the conduit opening when installed.

*This Page Intentionally Left Blank*

## How to Contact Precision Digital

- For technical support, please:  
Call: (800) 610-5239 or (508) 655-7300  
Fax: (508) 655-8990  
Email: [support@predig.com](mailto:support@predig.com)
- For sales support or to place an order, please contact your local distributor or:  
Call: (800) 343-1001 or (508) 655-7300  
Fax: (508) 655-8990  
Email: [sales@predig.com](mailto:sales@predig.com)
- For the latest version of this manual please visit [www.predig.com](http://www.predig.com)

