

ON DISPLAY

THE PRECISION DIGITAL MAGAZINE

Modbus®:
A Pathway
to Increased
Productivity

Ex-Proof
Meters
Cross Over to
Safe Areas!

**ARE YOU TEST
DRIVING YOUR PANEL
METERS?
Test Drive Ours!**

**BACK TO
BASICS:**
{PART 1}
Fundamentals
of 4-20 mA
Loops

**iPad Air
Giveaway**

Celebrating Our 1st Issue!
See back cover for details





Reader's Brief

We are pleased to introduce the first issue of our quarterly magazine **ON DISPLAY**. Our goal is to deliver practical and relevant information that helps customers make smarter decisions and streamlines their processes.

Among the editorial you will find discussions on topics customers request frequently, including fundamental training and solutions for specific applications. The "Letter from sales" section covers issues such as emerging trends, best practices, case studies and more.

Turn to this section each quarter to learn about recent efforts made to improve our customers' experience and satisfaction

- Precision Digital

Table of Contents



Modbus®: A Pathway to Increased Productivity

4

Explosion-Proof Meters Cross Over to Safe Areas!

10

Test Drive the Trident X2 on Your Desktop or Mobile Device Now

11

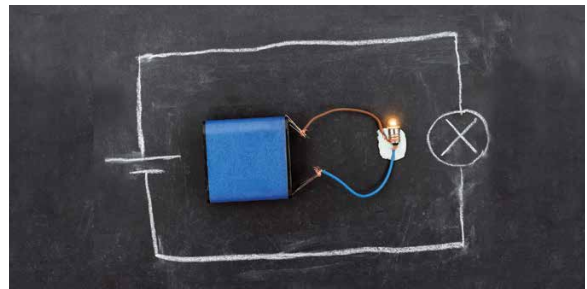

Back to Basics: Fundamentals of 4-20 mA Current Loops

12

contact us



U.S. & Canada
1-800-343-1001

International
1-508-655-7300



Tech Support
support@predig.com

Sales
sales@predig.com



Corporate Office
89 October Hill Road • Holliston, MA 01746 USA

Information at your fingertips

Catalog & Price List
iPad Apps



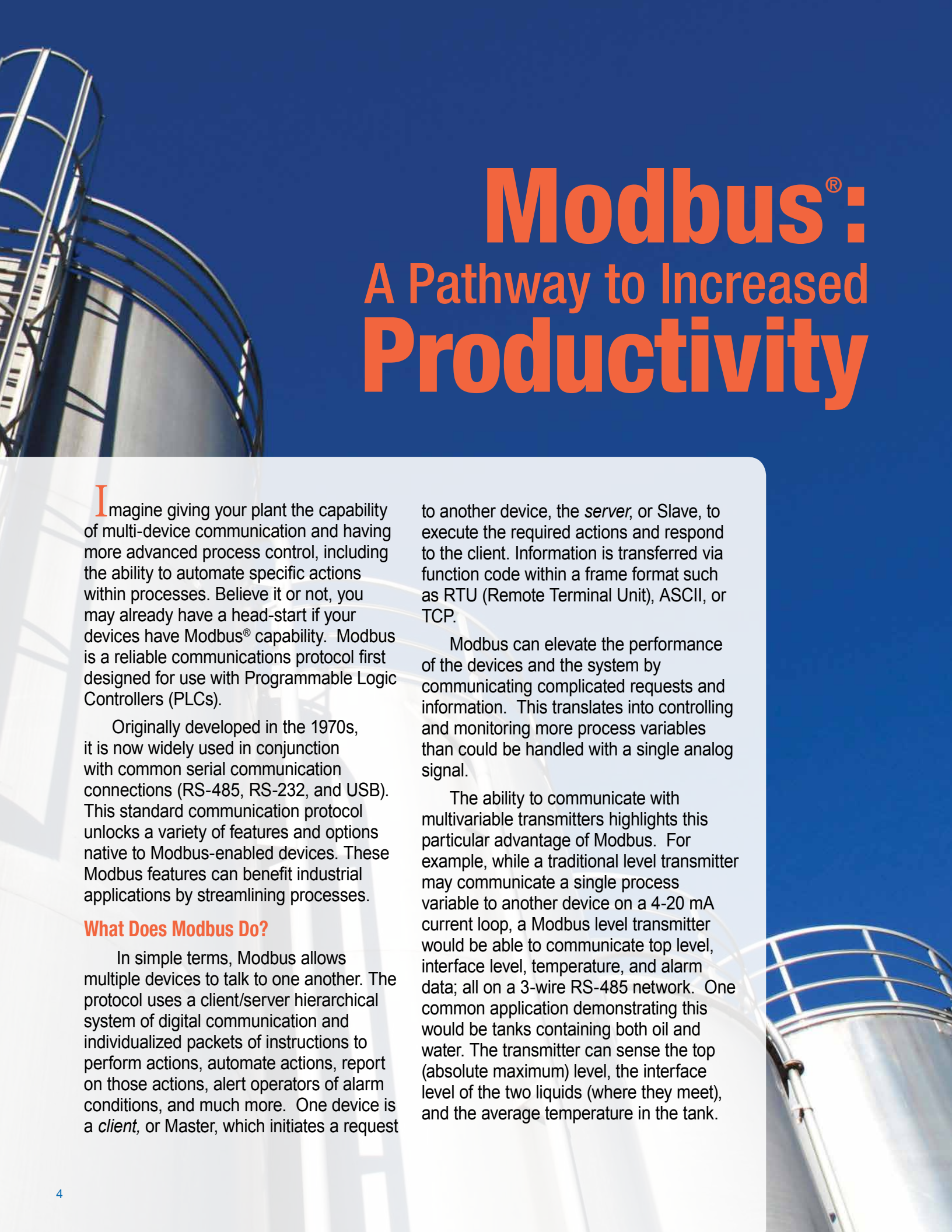

Modbus®: A Pathway to Increased Productivity

Imagine giving your plant the capability of multi-device communication and having more advanced process control, including the ability to automate specific actions within processes. Believe it or not, you may already have a head-start if your devices have Modbus® capability. Modbus is a reliable communications protocol first designed for use with Programmable Logic Controllers (PLCs).

Originally developed in the 1970s, it is now widely used in conjunction with common serial communication connections (RS-485, RS-232, and USB). This standard communication protocol unlocks a variety of features and options native to Modbus-enabled devices. These Modbus features can benefit industrial applications by streamlining processes.

What Does Modbus Do?

In simple terms, Modbus allows multiple devices to talk to one another. The protocol uses a client/server hierarchical system of digital communication and individualized packets of instructions to perform actions, automate actions, report on those actions, alert operators of alarm conditions, and much more. One device is a *client*, or Master, which initiates a request

to another device, the *server*, or Slave, to execute the required actions and respond to the client. Information is transferred via function code within a frame format such as RTU (Remote Terminal Unit), ASCII, or TCP.

Modbus can elevate the performance of the devices and the system by communicating complicated requests and information. This translates into controlling and monitoring more process variables than could be handled with a single analog signal.

The ability to communicate with multivariable transmitters highlights this particular advantage of Modbus. For example, while a traditional level transmitter may communicate a single process variable to another device on a 4-20 mA current loop, a Modbus level transmitter would be able to communicate top level, interface level, temperature, and alarm data; all on a 3-wire RS-485 network. One common application demonstrating this would be tanks containing both oil and water. The transmitter can sense the top (absolute maximum) level, the interface level of the two liquids (where they meet), and the average temperature in the tank.

Why Modbus?

Easily installed into an existing Modbus network, a Modbus scanner can display one or more variables with just a few serial communication wires. A ProVu® Super Snooper, for example, can poll (request information from) and display up to 16 process variables, requiring just three wires. In contrast, using analog outputs and digital meters would require numerous isolated 4-20 mA signal loops and corresponding isolated power supplies.

Another advantage of Modbus is the increased accuracy from digital measurement and display, due to the absence of analog signal inaccuracy or temperature drift in a Modbus system. The reading on the display represents exactly what the transmitter is detecting.

This enhanced accuracy also benefits flow rate and total systems. From industrial batching to oil & gas transport and custody transfer, accurate flow rates and totals are critical. Despite each analog signal used in a system contributing to overall system inaccuracy, many analog devices remain in service today. In fact, several accurate analog meters, transmitters, and displays can combine their allowable error specifications to cause problematic inaccuracy *in the system as a whole*.

Conversely, as a Modbus system expands with devices communicating exact flow and total values, *the more accurate the entire system will become*. Mixed oil & water tank gauging and precise oil & gas

flow measurement are just two general application examples of how almost any system can benefit from the use of Modbus serial communications. Other advantages include the simplicity of expanding the Modbus network vs. a traditional analog network, the ability of a centralized SCADA (Supervisory Control And Data Acquisition) system to communicate with multiple devices directly, and simplified device programming (made possible by computer software included with most Modbus devices).

However, the key to Modbus' ability to facilitate communication is its versatility as an application-layer protocol (capacity to *operate on a number of non-standardized physical layers* such as networks and buses). Since the wiring and

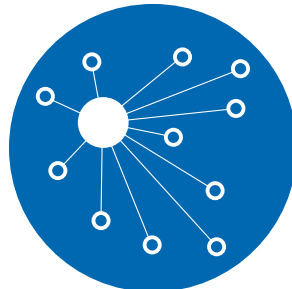

electrical specifications for each serial bus can vary, Modbus simply requires that all devices using the protocol communicate on compatible connections for the system to work. Converters are readily available that translate from one standard to another, such as RS-485-to-USB, so challenges in wiring a Modbus network can be minimized. Each of the various network types has its own advantages and limitations; more detailed information can be seen in the inset on the following page.

How to Set Up Modbus Devices

Setup for Modbus devices involves the protocol parameters, which often need to be changed from the factory defaults. Research your system requirements and, if possible, purchase equipment with the broadest ranges and most capability in order to minimize your system's limitations. Common considerations for setup include:

- **Device Address/Slave ID:** Programmable for 1 - 247 devices, each device on the network requires a unique address. This allows devices to know what data packets are relevant to them.
- **Baud Rate:** This is the communications speed in bits per second (bps). It must be identical for all devices on the network (between 300 - 19,200 bps).
- **Data Format:** The number of start bits, stop bits, and data bits used to configure the Modbus data packet (8-bit, 1 start bit, 1 or 2 stop bits, etc). It must match all devices on the network.
- **Parity:** Like the data format, this relates to the Modbus data packet configuration (Even, odd, or none with 1 or 2 stop bits). It should match on all devices.

Notice that many of the parameters need to match on *all devices in the system*. It is possible for the user to set additional specifications in a Modbus device, though the default settings are often sufficient for simple networks.

Byte-to-byte timeouts, transmit delays, polling and response times, and other

Leave the Climbing to Us

Install a Precision Digital Modbus® Scanner as a Tank-Side Indicator



LEVEL

INTERFACE LEVEL

DENSITY

TEMPERATURE

VOLUME



Super Snooper
Series



Take Advantage of Your Modbus Signal

By using the Modbus signal from your existing multivariable level transmitters, you will unleash a whole new dimension of display possibilities. Paired with a new Precision Digital Modbus Scanner you can display multiple variables including level, interface level, density, temperature and more. Best of all, you can leave the climbing to us.

Why Modbus Scanners?

- > Scan up to 16 PVs
- > Easy installation & setup
- > Display level in feet & inches*
- > SafeTouch® thru-glass buttons*
- > Display PV and tag name
- > 4-20 mA retransmission

* Available on select meters

1-800-343-1001 • www.predig.com/modbus

PRECISION DIGITAL CORPORATION *Since 1974*



settings are often available. Networks that are slow, have numerous network adapters, or are particularly complex may require these parameters to be set for non-default values. Once the network has been set up and tested, it is time to program the Modbus devices.

How Modbus Communicates

Modbus' client/server hierarchical system allows for Modbus devices to function as a *Master*, *Slave*, or *Packet Sniffer*. Most have a singular function, though some, such as Modbus Scanners, are capable of functioning in any one mode. *Master* mode, which controls the process, requests information from multiple *Slave* devices. The *Master* can scale the data from each *Slave* and displays critical process information.

A *Slave* device performs tasks as directed by the *Master* when polled by a *Master* device.

The most common command is to respond to the *Master* with basic information, such as the process variable and alarm states of the instrument. Alternatively, the *Master* can send data to a *Slave* device for it to act on, such as displaying a message or activating control outputs

As a *Packet Sniffer*, the device idles on the bus sniffing for packets of information which contain instructions and data passing between *Masters* and *Slaves*. A *Packet Sniffer* can display or act on data intended for another device without interfering with the network, which is great when adding additional displays to an existing Modbus system.

The information packets are referred to as Registers and are the primary means of communication between Modbus devices. The Modbus register specification defines how two devices communicate, detailing the list of instructions

and information locations for the associated device. It is important to remember that *every piece of information accessible by Modbus in a device has a Modbus register*.

Each register will have a data type and register number. For example, a Precision Digital PD6000 meter stores the process variable in registers 40001-40002 as a floating point variable. The Modbus register table for the PD6000 defines this and provides additional useful information (in this case, that it is a 5-digit "read only" register, and the allowable range of values in the register).

When configuring a Modbus network, the information in these tables is entered into the various devices that read information. For example, if using a Modbus scanner to read the values from a multivariable level transmitter, the scanner will be programmed with the transmitter Modbus Address/ Slave ID, plus the register number and data types for each piece

Common Modbus Network Connection Types



RS-485: This network is multi-drop, meaning it can have a large number of devices wired in parallel on the same network. It can function over long distances (up to 4,000 ft, or 1219 m). This communications method is common on industrial devices. Most personal computers do not have an RS-485 connection, so a USB or RS-232 converter is needed to connect to an RS-485 network to them.



RS-232: This is most commonly available as the 9-pin serial port common on older desktop computers. This communication method is still used when a single Modbus device needs to connect to an older piece of hardware that does not have a USB connection, or when wiring distances of up to 1,000 ft (305 m) are required.



USB: The Universal Serial Bus (USB) is a very common communication methods common on modern devices and personal computers. USB is a simple and easy way to connect a Modbus network or device to a personal computer. A number of standardized USB connector sizes exist, such as Type A, Type B, mini, and micro USB. USB device cables are very short in comparison to RS-232 and RS-485. Because of this, most devices in an industrial plant will be connected to an RS-485 or RS-232 network on the plant floor, and then use a USB converter where the USB enabled device or personal computer is located.



Ethernet: This network type is standard Ethernet protocol; the same used on an office internal computer network. The advantage of this protocol is that devices can be accessed from anywhere on the network, which is often installed throughout a facility. A web server device can also be accessed from anywhere with an Internet connection and proper network security credentials. These can be more complicated to setup and are often not necessary for gauging and process control applications. Ethernet and web server adapters/converters are available to connect the other network types to an Ethernet network. This allows other network types to connect to Ethernet by configuring just one Ethernet device, rather than every device in the network.

of information being read from the transmitter (e.g. top level, interface level, and temperature). Modbus tables are a tool for programming the Modbus *Master* device (the scanner in the previous example), and are only used when referencing the data from a Modbus *Slave* device being read by the *Master*. To someone unfamiliar with Modbus serial communications, the terms and tables can seem intimidating. It is important to remember that modern Modbus industrial devices are becoming easier to set up and more user-friendly, as they are designed for use by instrumentation technicians and are not just geared toward computer programmers and electrical engineers.

Once the system is set up, operators notice the benefits right away. For instance, portions of a level process now have a degree of automation that obsoletes the need to climb a tank or visibly check the process. Expanding on the mixed oil & water tank gauging and precise oil & gas flow measurement examples, your plant's efficiency can be increased in various ways with a Modbus Scanner. For example:

- Use *Snooper (Packet Sniffer)* Mode to add a tank side indicator at eye-level for a Modbus level transmitter being polled by a *Master* in the control room.
- Use *Snooper* Mode to add additional remote displays to a network with a Modbus scanner acting as the *Master*, and display the data at all operator locations.
- Use *Slave* Mode to display data sent to the scanner by a Modbus *Master* in the control room.

As you can see, Modbus is more than just a means for two or more devices to communicate digitally across various types of networks. Modbus allows devices to share more complex data with greater accuracy than possible with traditional process industry methods.

As an increasing number of Modbus devices replace analog

equipment in a system, more functionality is unlocked. Most importantly, by offering advanced control and ability to monitor more process variables, Modbus has the potential to increase the productivity of your entire operation.

by Bob Fedor - Marketing Communications and Joe Ryan - Product Manager
Precision Digital Corporation

Typical Modbus Application Example



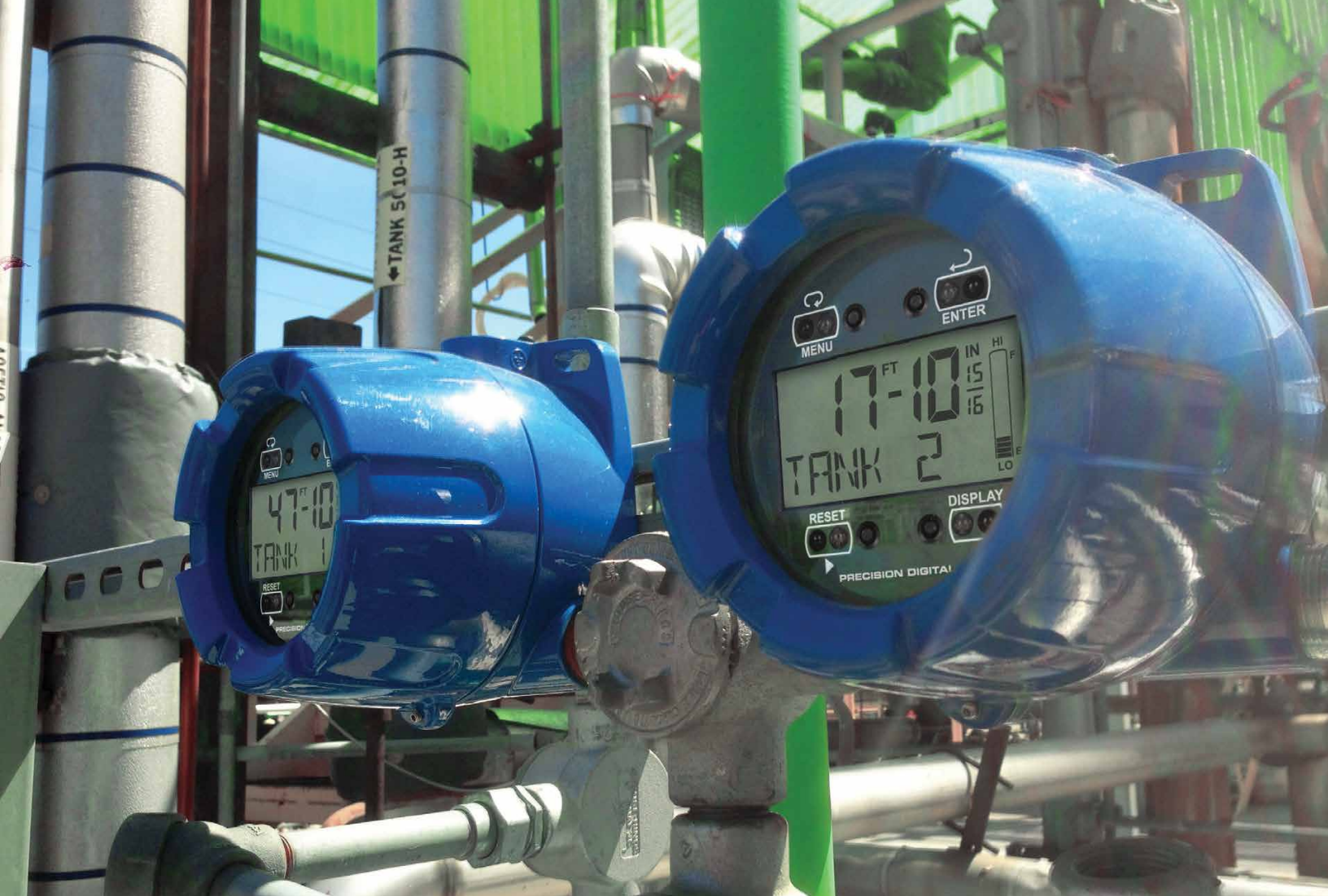

Robust Performance

The ProtEX Series continues to deliver a robust and efficient solution to hazardous areas around the world. With a full range of standard features and functionality, the ProtEX Series performs brilliantly in demanding and diverse applications.

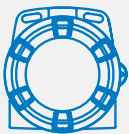

**RUGGED
NEMA 4X / IP68
ENCLOSURE**



**FULLY
APPROVED
EXPLOSION-PROOF**



**SUNLIGHT
READABLE
DISPLAYS**



**4-20 mA
AND ALARM
OUTPUTS**

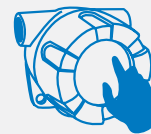

**SAFETOUCH®
THRU-WINDOW
PROGRAMMING**

See What ProtEX Has to Offer
www.predig.com/protex



Explosion-Proof Meters Cross Over to Safe Areas!



by Chuck Arcovitch -
U.S. Distribution Sales Manager
Precision Digital Corporation

➔ As the U.S. Distribution Sales Manager for Precision Digital, I travel all around the country training our distributor partners. I also gather feedback from distributors and end users that work in a wide range of process industries from oil & gas to water & wastewater.

I've found that most folks perceive Precision Digital as a manufacturer of reliable, high quality panel meters. That is certainly true! We've been making panel meters since 1974, and they are a major part of our business. What they don't always know is that we also manufacture field mounted and explosion proof products like the big blue display I'm holding in the picture next to this article. The device I'm holding here is part of our ProtEX-MAX Series.

The ProtEX-MAX is an explosion-proof instrument line with worldwide approvals for use in hazardous areas. However, in many of the installations of the ProtEX-MAX, it is used in a safe area, with no special hazardous area classifications. So, why use an explosion proof indicator?

It may seem like overkill to use an explosion-proof product in a safe area, but there are a number of advantages. The ProtEX-MAX provides a ready-to-go field mount solution that is extremely rugged. It can withstand almost any outdoor environment, daily wash downs, and being backed into by a truck. One plant operator asked me if the ProtEX-MAX instruments are fork lift proof! Is there a rating for

that? You get the point. In dirty, wet, dangerous, industrial process industry environments, overkill in the area of ruggedness is a good thing.



When training distributors, I always ask if all of their customers know they sell Precision Digital; which often gets a groan in response. Then, I ask them if their customers know about the Precision Digital rugged field mounted and explosion proof displays. To those who think of Precision Digital as a panel meter company, this gets their interest. So I tell our distributors to make sure all their customers understand the full scope of Precision Digital instruments available to them.

As a distributor, if you lead with explosion-proof many folks will tell you that they don't have indicators in classified areas. However if you lead with the ProtEX-MAX, the door may be open for more applications.

As a user, consider the ProtEX-MAX line the next time you have an instrumentation project, and decide if an easy to mount, extremely rugged meter or controller may be what you need. If so, then the ProtEX-MAX will be great solution.



You Test Drive Your Car. Why Not Test Drive Your Panel Meter?



Test drive the Trident X2 Process & Temperature meter featuring the largest 1/8 DIN display on the market, and see why it's time to upgrade your old panel meters. Check it out on your desktop or mobile device.

tvm.predig.com



 **TRIDENT**
Virtual Meter

{PART 1} BACK TO BASICS:

The Fundamentals of 4-20 mA Current Loops

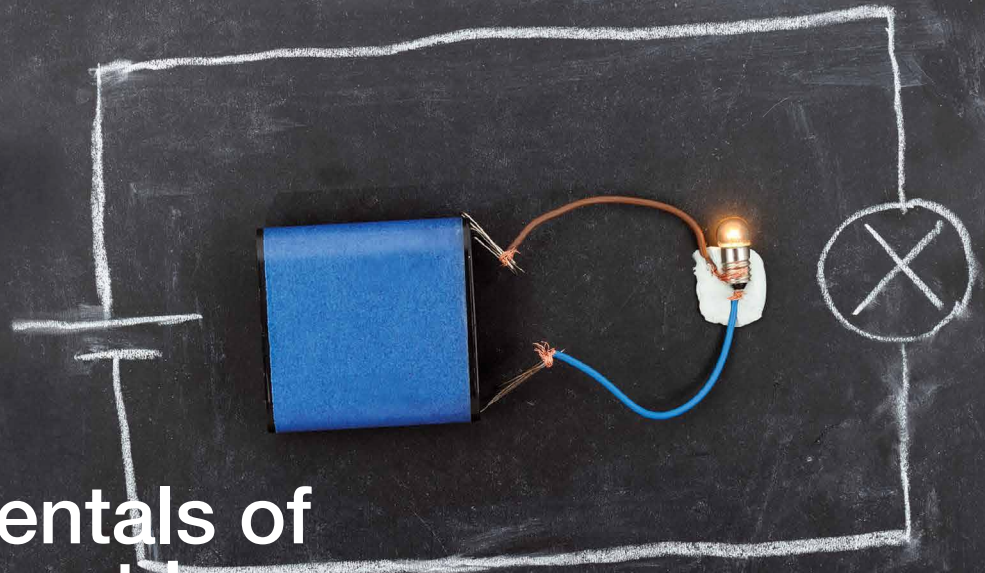

In the world of process control, there are a myriad of different types of process inputs. Thermocouples and RTDs provide direct temperature reading while digital signals such as Modbus® provide exacting control over process variables and display. Analog signals, where information about the process is transmitted via varying amounts of voltage or current, are the predominant type of input in industries requiring process control today. Of all possible analog signals that can be used to transmit process information, the 4-20 mA loop is, by far, the dominant standard in the industry.

As major as the 4-20 mA loop standard has become in the process control industry, many do not understand the fundamentals of its setup and use. Not knowing the basics could potentially cost

“Not knowing the basics could potentially cost you money...”

you money when it comes time to make decisions about process display and control. Having a grasp on the history, workings, pros and cons of the 4-20 mA loop will help you to understand why it is the dominant standard for the industry and allow you to make informed decisions about your process control.

What is a 4-20 mA Current Loop?

In order to understand what a 4-20 mA direct current (DC) loop is and how it works, we will need to know a little bit of math. Don't worry; we won't be delving into any advanced electrical engineering formulas. In

fact, the formula we need is relatively simple: $V = I \times R$

This is Ohm's Law. What this is saying is that the voltage (V) is equal to the current (I) multiplied by the resistance (R) (" I " stands for Intensité de Courant, French for Current Intensity). This is the fundamental equation in electrical engineering.

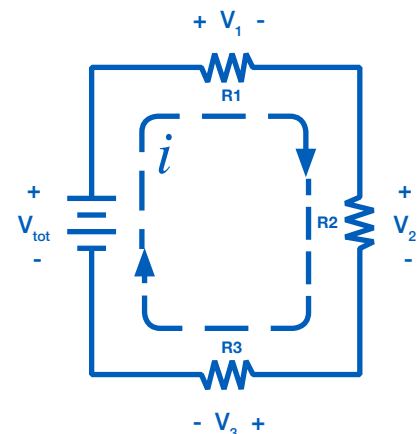

Consider the simple DC circuit above, consisting of a power supply and three loads. A current loop requires voltage to drive the current. This is provided by the power

supply, with the voltage of the supply labeled as V_{tot} . Current then flows through the loop, passing through each load. The voltage drop at each load can be calculated from Ohm's Law. The voltage drop V_1 across R_1 is:

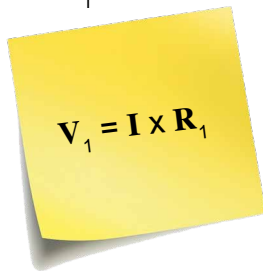
$$V_1 = I \times R_1$$

Every element in the loop either provides voltage, or has a voltage drop. However, the current, I is the same everywhere in the loop. This is the critical principle of the 4-20 mA loop. Current is the same in all places throughout the loop.

It may be difficult to understand why the current remains constant, so consider your home's water system as a comparison. There is a certain amount of pressure in the water pipes pushing the water towards your house. Voltage, in a similar fashion, acts as a pressure, pushing current through the circuit. When a tap inside your home is turned on, there is a subsequent flow of water. The flow of water is analogous to the flow of electrons, or current. The ability of the pressure to push the water through the pipes is limited by bends and restrictions in the pipe. These restrictions

limit the amount of flow in the pipe, similar to how a resistor limits the current. The flow through the pipe, and likewise the current through the wire, remains constant throughout the system, even though pressure, and likewise voltage, will drop at various points. This is why using current as a means of conveying process information is so reliable.

Components of a 4-20 mA Loop

Now that we have an understanding of how and why current is used, we can begin to understand what exactly the loop is for.

① Sensor

First, there needs to be some sort of sensor which measures a process variable. A sensor typically measures temperature, humidity, flow, level or pressure. The technology that goes into the sensor will vary drastically depending on what exactly it is intended to measure, but this is not relevant for this discussion.

② Transmitter

Second, whatever the sensor is monitoring, there needs to be a way to convert its measurement into a current signal, between four and twenty milliamps. This is where a transmitter will come into play. If, for instance, a sensor was measuring the



A Little Bit of History

Before the advent of electronic circuitry, process control was a wholly mechanical endeavor. Facilities used pneumatic control signals where controllers were powered by varying pressures of compressed air.

Ultimately, air compression of 3-15 psi became the standard for a few reasons:

- » Very expensive to engineer systems detecting pressure signals under 3 psi
- » Signals below 3 psi would be unrecognizable
- » Easier to differentiate a live zero (3 psi) signal from a failure in the system (0 psi)

In the 1950s, as electronic systems became less expensive, current input became the preferred and more efficient process control signal. The 4-20 mA range later became the standard for similar reasons as 3-15 psi did.

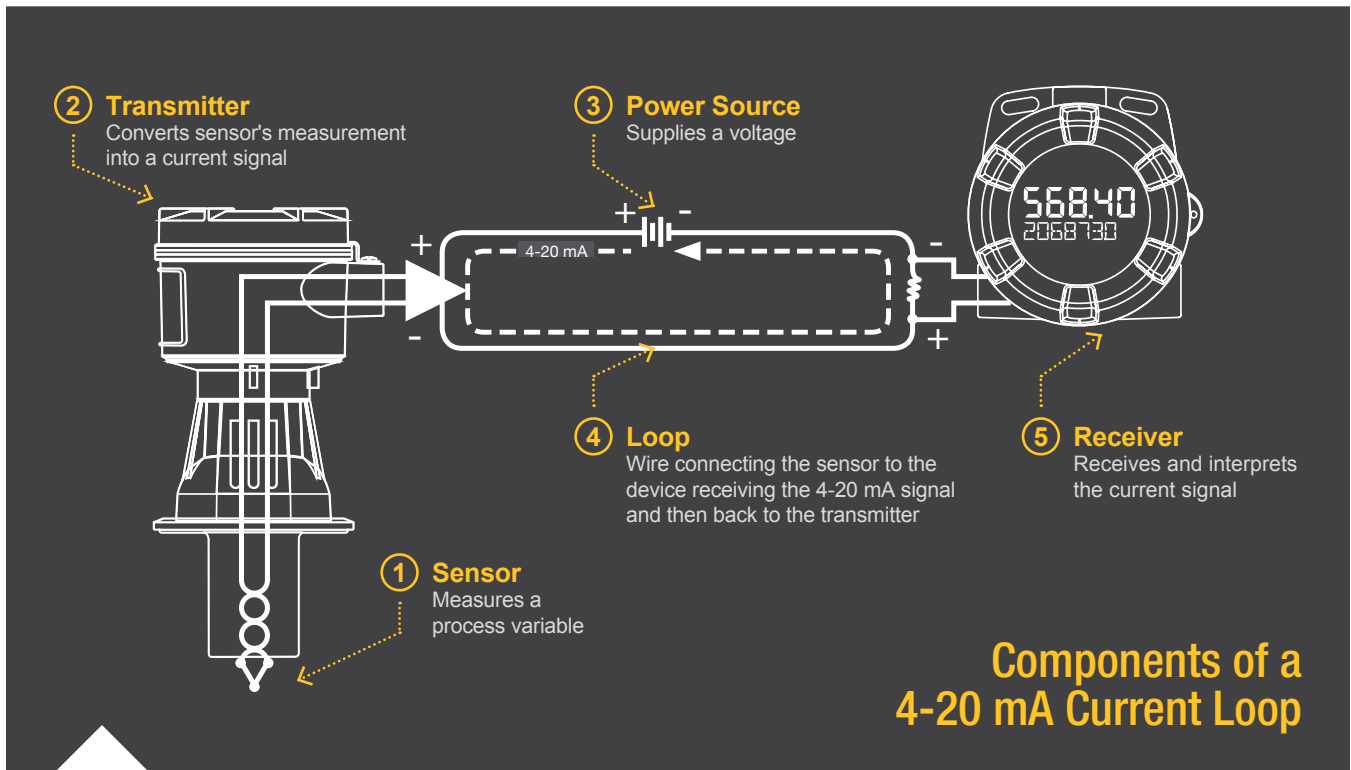

height of a fifty foot tank, the transmitter would need to translate zero feet as the tank being empty and then transmit a four milliamp signal. Conversely, it would translate fifty feet as the tank being full and would then transmit a twenty milliamp signal. If the tank were half full the transmitter would signal at the halfway point, or twelve milliamps.

3 Power Source

In order for a signal to be produced, there needs to be a source of power, just as in the water system analogy there needed to be a source of water pressure. Remember that the power supply must output a DC current (meaning that the current is only flowing in one direction). There are

many common voltages that are used with 4-20 mA current loops (9, 12, 24, etc.) depending on the particular setup.

When deciding on what voltage of power supply to use for your particular setup, be sure to consider that the power supply voltage must be at least 10% greater than the total voltage drop of the attached components (the transmitter, receiver and even wire). The use of improper power supplies can lead to equipment failure.

4 Loop

In addition to an adequate VDC supply, there also needs to be a loop, which refers to the actual wire connecting the sensor to the

device receiving the 4-20 mA signal and then back to the transmitter. The current signal on the loop is regulated by the transmitter according to the sensor's measurement. This component is typically overlooked in a current loop setup because wire is so intrinsic to any modern electronic system, but should be considered in our exploration of the fundamentals. While the wire itself is a source of resistance that causes a voltage drop on the system, it is normally not a concern, as the voltage drop of a section of wire is minuscule. However, over long distances (greater than 1,000 feet) it can add up to a significant amount, depending on the thickness (gauge) of the wire.

5 Receiver

Finally, at someplace in the loop there will be a device which can receive and interpret the current signal. This current signal must be translated into units that can be easily understood by operators, such as the feet of liquid in a tank or the degrees Celsius of a liquid. This device also needs to either display the information received (for monitoring purposes) or automatically do something with that information. Digital displays, controllers, actuators, and valves are common devices to incorporate into the loop.

These components are all it takes to complete a 4-20 mA current loop. The sensor measures a process variable, the transmitter translates that measurement into a current signal, the signal travels through a wire loop to a receiver, and the receiver displays or performs an action with that signal.

Pros & Cons of 4-20 mA Loops

Part of the challenge of working in an industry which requires process control is determining if the pros outweigh the cons. Making the right decision can save both time and money.



- ✓ The 4-20 mA current loop is the dominant standard in many industries.
- ✓ It is the simplest option to connect and configure.
- ✓ It uses less wiring and connections than other signals, greatly reducing initial setup costs.
- ✓ Better for traveling long distances, as current does not degrade over long connections like voltage.
- ✓ It is less sensitive to background electrical noise
- ✓ Since 4 mA is equal to 0% output, it is incredibly simple to detect a fault in the system.



- ✗ Current loops can only transmit one particular process signal.
- ✗ Multiple loops must be created in situations where there are numerous process variables that require transmission. Running so much wire could lead to problems with ground loops if independent loops are not properly isolated.
- ✗ These isolation requirements become exponentially more complicated as the number of loops increases.

Summary

The 4-20 mA current loop is the prevailing process control signal in many industries. It is an ideal method of transferring process information because current does not change as it travels from transmitter to receiver. It is also much simpler and cost effective. However, voltage drops and the number of process variables that need to be monitored can impact its cost and complexity. By knowing these fundamentals you will be able to make more informed decisions about process control in your facility which could affect your bottom line.

by Simon Paonessa - Technical Writer
and Bruce McDuffee - Technical Writer
Precision Digital Corporation

iPad Air Giveaway



Register at www.predig.com/magazine



Celebrating the
1st issue of
**ON
DISPLAY**
THE PRECISION DIGITAL MAGAZINE

Fill out the entry form for a chance to win an iPad Air. No purchase is necessary. Only one entry per person will be accepted. Precision Digital reserves the right to disqualify any entry for any reason without notice. All entries must be received by 11:59 PM EST on 04/30/2015. Drawing will be held on 05/01/2015. The lucky winner will be notified via email.

Q1 2015